

Contents
THE VISIONS OF DANIEL
FULFILLED

INTRODUCTION		Page 1
CHAPTER ONE	Daniel One Through Six	Page 5
CHAPTER TWO	Daniel Seven	Page 15
CHAPTER THREE	Daniel Eight	Page 29
CHAPTER FOUR	Daniel Nine	Page 37
CHAPTER FIVE	Daniel Ten	Page 49
CHAPTER SIX	Daniel Eleven	Page 53
CHAPTER SEVEN	Daniel Twelve	Page 66
CHAPTER EIGHT	Summary of Daniel	Page 77
Appendix A	The Maccabees	Page 92
Appendix B	Early Date Authors of Revelation	Page 95
Bibliography		Page 96

The Visions of Daniel

Introduction

The hypothesis defended in this thesis is as follows: (1) the visions of Daniel are each a pre-told history, (2) each of these pre-told histories is in chronological order, (3) there is no warrant for inserting a gap of thousands of years in any of the chronologies, and (4) each vision has already been fulfilled. If these propositions are true, then this is compelling evidence that Daniel was written by Daniel at the time the book indicates (before or about 530 B.C.) and was inspired by the Holy Spirit. The author has searched with an open mind, and can find no warrant for inserting a gap in the text of Daniel that would stretch into our future.

This interpretation is called the “preterist” interpretation of prophecy. Not all Preterists will agree on every detail of this interpretation of Daniel (or of Revelation). Some are called “Partial Preterists,” some are called “Full Preterists,” and some are called “Orthodox Preterists.” (This is not to say that Partial Preterists are not orthodox, but some have questioned the orthodoxy of some Full Preterists because they deny a future bodily return of Christ.) The author generally agrees with R.C. Sproul and Gary DeMar, and calls himself an “Orthodox Preterist” because he sees all of the Olivet Discourse, Daniel, and Revelation as fulfilled; but also believes in the final bodily return of Christ to fulfill the Lord’s Prayer that says, “Thy Kingdom come; Thy will be done on earth as it is in heaven.” Full Preterists say that took place in A.D. 70. The author sees that His Kingdom came when Christ came, when Christ cast out demons, when Christ destroyed Jerusalem, when Rome was converted, when

The Visions of Daniel

the Reformation came, etc. But it must still come in the absolute sense. Partial Preterists see the Olivet Discourse and Revelation as partially fulfilled and the verses about Christ's coming as still future.

Quotes from all commentaries, except those noted in footnotes, can be found on the internet at <http://eword.gospelcom.net/comments/>

This thesis proceeds on the presupposition that all Scripture is given by inspiration of God. Those who presuppose that God never spoke by the prophets, Jesus, and the apostles, will never be persuaded "though one rose from the dead." These "wolves" and "mockers" who have "crept in unnoticed" were "long ago marked out for this condemnation..." (Jude 4 NKJV). These "spots in your love feasts" (Jude 12 NKJV) claim that they are more "enlightened" than the Scripture and that someone other than Daniel wrote the book hundreds of years after Daniel's time. By making such a claim, they are in effect making themselves the "true" prophets. The faithful, on the other hand, believe they are false prophets and that Daniel was a true prophet because Jesus said he was and also because the universal church agreed.

Therefore when you see the "abomination of desolation," spoken of by Daniel the prophet, standing in the holy place" (whoever reads, let him understand), then let those who are in Judea flee to the mountains (Matthew 24:15 NKJV).

Luke 21:20 interprets "abomination of desolation" to mean "Jerusalem surrounded by armies," and Jesus said it would happen in *that* generation (Mat 24:34). Matthew gave the literal statement of Jesus in Aramaic and Luke gave the interpretation in Greek.

But when you see Jerusalem surrounded by armies, then know that its desolation is near. Then let those who are in Judea flee to the mountains (Luke 21:20,21 NKJV).

The Visions of Daniel

Another example of Luke is in his interpretation of what the people said at the Triumphal Entry. Mathew gives the literal statement of the Aramaic words of the people when they said, “Hosanna to the Son of David! ‘Blessed *is* He who comes in the name of the LORD!’ Hosanna in the highest!” (Mat 21:9NKJV), and Luke interprets it for the Gentiles with, “Blessed *is* the King who comes in the name of the LORD! Peace in heaven and glory in the highest!” (Luke 19:38 NKJV). “Hosanna” means “peace in heaven and glory in the highest.”

Both the Jews and the early Church Fathers accepted the Book of Daniel as authentic. But, as illustrated in Appendix B and C, modern Jews and modernist scholars reject its authenticity based on the assumption that there is no way God could speak through a prophet and foretell the future as Daniel claims. Before the Renaissance, history before Christ was called the “dark age,” and the time after Christ was called the age of light. Humanists now divide history into the classical period (of Greece and Rome), the dark ages from the fall of Rome to the Renaissance, and the current age of light. Humanists that Christianity brought on the dark, but they fail to see that it was the invasion of the illiterate barbarians upon Roman civilization that was the real cause. It was Christianity that saved civilization.¹ Modern men think they are so smart that they have forgotten how they got that way, and have decided they no longer need the God of Christianity that saved civilization. “Because, although they knew God, they did not glorify *Him* as God, nor were thankful, but became futile in their thoughts, and their foolish hearts were darkened” (Rom 1:21 NKJV). If modern man understood and believed the interpretation of Daniel given in

¹ Thomas Cahill documents how the Celtic monks saved civilization in *How The Irish Saved Civilization*. New York: Random House, 1995.

The Visions of Daniel

this treatise, they would perhaps be persuaded to come to the Light that lights every man that comes into the world.

The Visions of Daniel

CHAPTER ONE Daniel Chapters One Through Six

Daniel was carried to Babylon as a captive from Jerusalem in 606 BC. Jerusalem was destroyed by Babylon 20 years later in 586 BC. Jewish captives returned to Jerusalem in 536 BC, seventy years after Daniel was taken there. Daniel was still alive after 73 years in Babylon and he must have been around ninety years of age. Cyrus the Mede/Persian conquered Babylon in 536 BC.

Behold, I will stir up the Medes against them (Isaiah 13:17ff NKJV).

Babylon had conquered the entire Middle East. Ancient historians² said that its wall was 15 miles on each side, 300 ft high, 80 ft thick, extending 35 ft below the ground so that enemies could not tunnel under; built of brick one foot square and 3 or 4 inches thick; 1/4 mile of clear space between the city and the wall all the way around; the wall protected by wide and deep moats (canals) filled with water; 250 towers on the wall, guard rooms for soldiers; 100 gates of brass. The city was divided by the Euphrates into two almost equal parts; both banks guarded by brick walls all the way, with 25 gates connecting streets and ferry boats; one bridge, on stone piers, 1/2 mile long, 30 ft wide, with drawbridges which were removed at night. There was a tunnel under the river, 15 feet wide, 12 ft high. Excavations of recent years have, to a large extent, verified the seemingly fabulous accounts of ancient historians³.

² The descriptions of Bablon here are taken from Halley, Henry H. *Halley's Bible Handbook*, Grand Rapids: Zondervan, 1965.

³ Ibid.

The Visions of Daniel

Isaiah foretold the defeat of Babylon over a hundred years beforehand. The Medes overtook Babylon at the time of Daniel in Chapter Five.

Since the author is focusing on the visions that Daniel himself had, he will not comment in detail on Chapters One through Six. It should be noted that in each one of the chapters of Daniel the Holy Spirit is dealing with government. The issue in Chapter One is how the believer should deal with being a captive to an evil system. Can one be in the world and yet not of it? Chapter One shows how one can actually be trained in pagan schools and yet not be defiled. One can even be an employee of heathen governments and yet remain pure. Daniel and his friends determined not to defile themselves with the king's meat. They defied the king's command without disobeying God. They obeyed the prophet Jeremiah and prayed for the peace of the city to which God had sold them into slavery.

And seek the peace of the city where I have caused you to be carried away captive, and pray to the LORD for it; for in its peace you will have peace (Jer 29:7 NKJV).

In Chapter Two, King Nebuchadnezzar dreams a dream, which only Daniel can interpret. He dreams of an image of a man with a head of gold, arms and chest of silver, belly of brass, legs of iron, and feet of clay and iron mixed. A little stone cut out of a mountain without hands flies through the air and smites the image on the feet. The whole image crumbles to dust and is blown away by the wind. The little stone then grows until it becomes a great mountain and fills the whole earth.

Daniel then interprets the dream. Babylon is the head of gold. After that would come another empire. It came as the kingdom of the Medes and Persians depicted as a kingdom of silver. After that would come Greece, depicted as the belly of brass. After that would come Rome, depicted as the legs of iron. The whole

The Visions of Daniel

foundation (the feet) is built on a mixture of iron and clay. Christ's kingdom is the little rock. It grows and grows until it fills the whole earth. This was to happen, not in our future, but in the days of the fourth kingdom, Rome. Daniel says, “And *in the days of these kings* the God of heaven will set up a kingdom which shall never be destroyed; and the kingdom shall not be left to other people; it shall break in pieces and consume all these kingdoms, and it shall stand forever” (2:44 NKJV emphasis added). Christ fulfilled this vision given to Nebuchadnezzar. The little stone has not yet filled the whole earth, but the fact that it has already destroyed Rome is a token of evidence that it shall continue to grow until this vision is completely fulfilled. It clearly says it would happen “in the days of these kings” that are enumerated in the vision. Christ came, ascended to the Father, and received His kingdom. Since then it has been growing and growing until it shall fill the whole earth with the “knowledge of the glory of the Lord” (Hab 2:14). To insert a gap of thousands of years here, and say that this did not happen in the context of those kings⁴ mentioned in Chapter Two, is not warranted by the text of the passage.

In Chapter Three, Daniel's three friends demonstrated when it is necessary to disobey the authorities in order to obey a higher authority. They would not bow to the image of man. The worship of “man’s image” is humanism. Humanism results in the worship of the state as god. A Biblical study of history shows that all other religions and philosophies, except Christianity, end up in the worship of the state in the place of God. Political correctness becomes a higher law than God's law. This is

⁴ Although the head depicts Babylon, Daniel says the head is Nebuchadnezzar. Therefore, Daniel sees each kingdom as a king. Perhaps he is envisioning the Satanic principality over Babylon and Nebuchadnezzar.

The Visions of Daniel

a theme that runs throughout the Bible from the Tower of Babel to Caesar, the beast. Josephus said that the reason the people built the Tower of Babel was based on their fear of another flood. They decided to save themselves in such an event by waterproofing the Tower. It would then not be necessary to keep the Noahic Covenant and trust God's promise not to send another flood. Statists seek to do the same. They say it is cruel to have to trust God for security. When men say that the law of the state is the highest law, it is the same as saying, "We have no king but Caesar." It is to worship the image of the beast and to take his mark. God is showing us through the three friends of Daniel, that if we stand faithful, we cannot be consumed (as opposed to the beast that was to be consumed in the fire). As the song says, "They wouldn't bend, they wouldn't bow, and they wouldn't burn." God's kingdom is eternal and will eventually prevail over all and replace all others.⁵

In Chapter Four, Nebuchadnezzar has another dream interpreted by Daniel. The fact that only Daniel can interpret these visions illustrates that only the Bible prophets have the answer to the dreams of men. God does this by means of those like Zechariah who have "understanding in the visions of God" (2 Chron 26:5 NKJV).

In Chapter Four, the king dreams that he is a tree that is cut down until "seven times" come over him. He later fulfills the vision by going mad until he recognizes that the Most High is the true ruler of men and kings. Could it mean that since Nebuchadnezzar is the titular head of the nations, then what happened to him shall happen to the body of nations? Could it mean that what happened in history to the

⁵ This is not to say that the Kingdom of God is to be a worldly kingdom whose goal is to rule the world in a one-world government. There will always be individual nations, but these nations must write their laws in conformity to the law that proceeds from Zion, and receive Christ as Lord of Caesar (the state).

The Visions of Daniel

head shall happen also to the body? Could it be that what Daniel tells us in this chapter was not just history but was also prophecy? Could the madness of the current "new morality" be replaced some day in history with all nations giving glory to God and acknowledging His law as the law that must be the law of the land? Could it be that their reason shall return to them when they repent and submit to King Jesus?

Many Scriptures seem to indicate that this return to reason shall happen. Psalm 22:27 says, "All the ends of the world shall remember and turn to the LORD, and all the families of the nations Shall worship before You" (NKJV). Habakkuk 2:14 says, "For the earth will be filled with the knowledge of the glory of the LORD, as the waters cover the sea" (NKJV). Christ is told, "Ask of Me, and I will give You The nations for Your inheritance, And the ends of the earth for Your possession" (Ps. 2:8 NKJV). Dare one assume that the prayer of Christ will not be answered? Is it not more reasonable to assume that every prayer that is prayed by the Holy Spirit (Romans 8:26) through the Church shall be answered? His kingdom shall come, and His will shall be done on earth as it is in heaven. "Yes, all kings shall fall down before Him; All nations shall serve Him" (Ps 72:11 NKJV).

Chapter Five shows what happens to those nations that mock God's church. Belshazzar is mocking God's people by partying with the holy vessels taken from Solomon's Temple when the handwriting appears on the wall, and he is found wanting. The Medes take over the kingdom as proof that the prophets were right (Isa 45:1ff). Nations today can mock the Church because of being Christians in name only. Jude writes of the "mockers" who profess faith but are counterfeit.

The Visions of Daniel

One good thing about the kingdom of the Medes and Persians was that they honored "law." The law had more power than the king. This is a step in the right direction. But it still does not go far enough, because it does not bow to the King of Kings. The law of the land must be the one that proceeds from Zion.⁶ (Hebrews 12:22 says believers have come to Zion and calls it the city of God and the heavenly Jerusalem. The law of the land must proceed from God's throne.)

Chapter Six deals with Daniel in the lions' den. The law of the Medes and Persians could not be changed. Even the king could not change it. That is good, but that good thing was used against Daniel. Good things can be used against the Church. Though the Constitution of the United States is the best one ever written, it can still be "used" against God's law. The main problem with the U.S. Constitution is that it makes "we the people" the authority in charge. To make God the Supreme Authority of the land it needs to be amended to say, "We the people, under the Triune God of the Bible." Nevertheless, until that happens, God shall deliver us from our enemies, their "law," and their lions.

Some say that Christians should not concern themselves with politics and culture. They say we should concern ourselves with heaven and personal salvation only. The Bible, however, deals mainly with this earth and not mainly with heaven. It says the meek shall inherit the *earth*. The purpose of redemption is to restore paradise as it was in Eden. God's Kingdom is destined to come in its finality to earth. In each of the visions of Daniel, government is the subject. The same is true in each

⁶ Micah 4:2 says, "Many nations shall come and say, 'Come, and let us go up to the mountain of the LORD, To the house of the God of Jacob; He will teach us His ways, And we shall walk in His paths.' For out of Zion the law shall go forth, And the word of the LORD from Jerusalem" (NKJV).

The Visions of Daniel

historical chapter. The main purpose in life is not to go to heaven; the main purpose in life is to glorify God and bring heaven to earth. The Lord taught us to pray, “Thy kingdom come; Thy will be done *on earth* as it is in heaven.” Every single hero in the Bible was concerned with politics and life on earth.

Take for example Noah. He was told that he and (we) his descendants were to enforce capital punishment (Gen 9:6), Abraham was promised a land, Joseph was made a ruler, Moses ruled a nation, the judges judged, David fought and reigned, Elijah and the prophets dealt mainly with rulers, and “the kingdoms of this world have become the kingdoms of our God and His Christ” (Rev. 11:15). Jesus said that all authority in both heaven *and* in earth has been given to Him. Since He came and until He comes again, the time has come for the government to be “given to the people, the saints of the Most High” (Dan 7:27 NKJV).

Now therefore, be wise, O kings; Be instructed, you judges of the earth.
Serve the LORD with fear, And rejoice with trembling (Ps 2:10,11 NKJV).

Visions

A few words about visions should be mentioned before covering in detail the visions of Chapters Seven through Twelve. According to Numbers 12, visions and dreams are given in symbols and “dark sayings.”⁷ In visions, stars are not stars. They are, for example in Joseph’s dream, metaphors for the leaders of Israel. In Pharaoh’s dream, Joseph says seven fat cows are not cows, but are seven years of plenty. Horns are rulers or symbols of power, a thousand years is an indeterminate time, and beasts are empires.

⁷ And he said, Hear now my words: If there be a prophet among you, *I* the LORD will make myself known unto him in a vision, *and* will speak unto him in a dream. My servant Moses *is* not so, who *is* faithful in all mine house. With him will I speak mouth to mouth, even apparently, and not in dark speeches...(Num 12:6-8).

The Visions of Daniel

Moses gives us this rule of interpretation in Numbers Chapter Twelve. God tells us there that He speaks to Moses face to face, but to the prophets in visions and dreams. God did not speak to Moses the same way He spoke to the prophets. To Moses He spoke face to face and plainly, and not in dark sayings. God seems to equate visions and dreams with dark sayings.

Then He said, "Hear now My words: If there is a prophet among you, *I*, the LORD, make Myself known to him in a vision; I speak to him in a dream. Not so with My servant Moses; He *is* faithful in all My house. I speak with him face to face, Even plainly, and not in dark sayings; And he sees the form of the LORD" (Num 12:6-8 NKJV).

Therefore, to interpret the symbols or "dark sayings" of a vision literally is to violate the rules. Even when Peter saw the sheet full of unclean animals, God did not speak to him plainly. He did not understand until Gentiles knocked on the door. The unclean animals were a symbol of the Gentiles. God was using symbols to tell him that it was okay for Peter to go into the house of a Gentile because God had made that Gentile clean.

As an example of this, in Daniel Chapter Eight, the little horn grows up to the stars of heaven and throws some of them down. This horn has eyes and a mouth. I should hope no one would take this literally. The horn is a ruler who throws down other rulers and tramples them, so to speak. Therefore, since it is a vision, the mark of the beast has to be something symbolic. Buying and selling must be something symbolic. Jesus said, in Revelation 3, "Buy of me the gold that does not perish" (3:20 NKJV). Can one do that literally? What He means is that we are to worship Him in Spirit and in truth. That is buying and selling in vision terminology. He sells, we buy. James Jordon has pointed out that to not be able to "buy or sell" means "not

The Visions of Daniel

allowed to do business in God's store.”⁸ It meant being thrown out of the synagogue. It meant, "not allowed to worship in the synagogue." Many Jewish leaders believed in Jesus, but secretly for fear of the Jews. They would be cast out of the synagogue. To take the mark of the beast was to *agree* with the chief priests when they said, "We have no king but Caesar." Caesar was the beast. To worship his image in this way was to take his mark. It was a spiritual mark just as the seal of God was/is. If they refused this mark and proclaimed Christ as Caesar's King, they could be ostracized.

We must, however, be aware of the genre of literature. Some sections of a vision speak literally and explain some of the symbols. Only selected men in the Bible had this gift of interpretation of visions. Joseph, Daniel, and Zechariah⁹ are examples of men "who had understanding in the visions of God" (2 Chron 26:5 NKJV). The apostles, especially Paul, were also given greater understanding. They unveiled the mystery that had been hidden from the ages.

As for these four young men, God gave them knowledge and skill in all literature and wisdom; and Daniel had understanding in all visions and dreams (Dan 1:17).

In the current age, some have better understanding in the visions of the prophets than others. Daniel had understanding in all literature and visions. It is not enough just to know the Bible. We must also be like Daniel and know *all* literature. That is why we also need to read history and commentaries. Those who say they only read the Bible do not follow the example of Daniel. Peter said, "Knowing this first, that no prophecy of Scripture is of any private interpretation" (2 Pet 1:20 NKJV). No man is an island. It is pride to say and think that one does not need others in the church to help get understanding. God put teachers in the church for that purpose.

⁸ Jordon, James B. *Behind The Scenes: Orientation In The Book Of Revelation*. Biblical Horizons, Niceville, FL 1995.

⁹ Uzziah "sought God in the days of Zechariah, who had understanding in the visions of God." (2CH 26:5)

The Visions of Daniel

As we enter this study of Daniel's visions, let us cry out to God for the "Spirit of wisdom and revelation in the knowledge of Christ." Let us pray that we might have open minds.

The Visions of Daniel

CHAPTER TWO Daniel Chapter 7

1 In the first year of Belshazzar king of Babylon Daniel had a dream and visions of his head upon his bed: then he wrote the dream, *and* told the sum of the matters.

2 Daniel spake and said, I saw in my vision by night, and, behold, the four winds of the heaven strove upon the great sea.

3 And four great beasts came up from the sea, diverse one from another.

4 The first *was* like a lion, and had eagle's wings: I beheld till the wings thereof were plucked, and it was lifted up from the earth, and made stand upon the feet as a man, and a man's heart was given to it.

5 And behold another beast, a second, like to a bear, and it raised up itself on one side, and *it had* three ribs in the mouth of it between the teeth of it: and they said thus unto it, Arise, devour much flesh.

6 After this I beheld, and lo another, like a leopard, which had upon the back of it four wings of a fowl; the beast had also four heads; and dominion was given to it (KJV).

This vision took place in the first year of Belshazzar. That was around 555 BC. Daniel was now an old man. He had been in Babylon for fifty years.

The vision of Chapter Seven corresponds to Nebuchadnezzar's dream of the image in Chapter Two. Daniel interpreted the image in Chapter Two to represent four empires. The head was Babylon. The chest and arms were the Medes and the Persians.¹⁰ The belly was Greece, and the legs were Rome. The little stone was Christ and his kingdom that would come in the days of Rome. It has been growing ever since, and will eventually fill the whole earth.

In the vision of Chapter Seven, the four empires, instead of being seen as a human image, are represented as beasts rising from a sea of humanity. God has many folds to his wisdom. It is "manifold" (EPH 3:10 NKJV). Beasts eat one another and

¹⁰ Some say that the second kingdom was the Medes, the third was the Persians, and the fourth was Greece. That interpretation allows them to deny the inspiration of Daniel by claiming the book was written after the fact. The problem with this is that the kingdom of the Medes and Persians was a single kingdom with Cyrus as head. Cyrus was half Mede and half Persian.

The Visions of Daniel

live on instinct rather than reason. Man, desiring to be a god, becomes a tyrannical beast. The first beast looked like a lion and represented Babylon. The second looked like a bear and represented Medo/Persia. The third looked like a leopard and represented Greece. The fourth was different from the others and represented Rome.

Head of gold = Lion = Babylon

Chest of silver = Bear = Medo/Persia

Belly of brass = Leopard = Greece

Legs of iron = Different = Rome

This prophecy was fulfilled with the coming of each of these empires. The Babylonian empire came to an end in 536 BC. The Medo-Persian empire came to an end in 331 BC. Immediately upon the death of Alexander, the Greek empire was divided among his four generals. That epoch was eclipsed by 63 BC when the Roman general Pompey entered Jerusalem. Later came the eternal Kingdom of God.

The Fourth Beast

Dan 7:

7 After this I saw in the night visions, and behold, a fourth beast, dreadful and terrible, exceedingly strong. It had huge iron teeth; it was devouring, breaking in pieces, and trampling the residue with its feet. It was different from all the beasts that were before it, and it had ten horns (NKJV).

This fourth beast was the Roman Empire. David Chilton¹¹ suggests that the ten horns are the ten provinces of the empire. Each province had a king that was under Caesar. They were 1. Italy 2. Achaia 3. Asia 4. Syria 5. Egypt 6. Africa 7. Spain 8. Gaul 9. Britain 10. Germany.

¹¹ Chilton, David. *Days of Vengeance*. Dominion Press, Tyler, Tx. 1987

The Visions of Daniel

John saw this same beast in Revelation 13 and 17, but John saw even more details about it. He saw that it had the characteristics of the other three beasts, but was different.

Then I stood on the sand of the sea. And I saw a beast rising up out of the sea, having seven heads and ten horns, and on his horns ten crowns, and on his heads a blasphemous name. Now the beast which I saw was like a leopard, his feet were like the feet of a bear, and his mouth like the mouth of a lion. And the dragon gave him his power, his throne, and great authority. I saw one of his heads as if it had been mortally wounded, and his deadly wound was healed. And all the world marveled and followed the beast (Rev 13:1,2 NKJV) (See also Rev 17).

Chilton also suggests that the seven heads were the first seven Caesars. They were Julius, Augustus, Tiberius, Caligula, Claudius, Nero, and Galba. There are varying interpretations of the wounded head. Some say it represents the civil wars at the time of Nero. Rome seemed to be perishing, but came back to life. It seems more likely that it is speaking of the murder of Julius. He represented the ambition that changed Rome from a republic to an ambitious empire. When the republican senators killed him, it seemed that the head was dead and republicanism was secured. But it came back to life in the form of Augustus with more power and fervor than ever before. All the world then marveled and followed Caesar. Augustus said, "Salvation is to be found in none other save Augustus, and there is none other name under heaven given to men by which they must be saved."¹² He brought worldwide peace. It was at this time that Christ was born.

The Little Horn

Dan 7:

8. I was considering the horns, and there was another horn, a little one, coming up among them, before whom three of the first horns were plucked out by the roots. And

¹² Quoted from Ethelbert Stauffer's *Christ and the Caesars*, pp. 81 - 89. [Philadelphia: Westminster Press, 1955]. In Acts 4:12, Peter directly contradicts this claim of Caesar by replacing Augustus with Christ.

The Visions of Daniel

there, in this horn, were eyes like the eyes of a man, and a mouth speaking pompous words (NKJV).

This little horn could represent the dynasty of Caesars. That dynasty, backed by the Dragon, spoke pompous words by receiving the worship of men as if they were gods. They had the eyes of a man in that they were superb politicians. They knew how to win friends and influence people to enhance their power. The three horns that were uprooted could refer to Brutus, Cassius, and Mark Antony. Augustus Caesar defeated all three. Brutus ruled Gaul for a time, and later Achaia. Cassius ruled Syria. Mark Antony ruled Egypt.

The little horn in this chapter could also represent Herod. James Jordan gives convincing evidence of this interpretation.

Herod the Great will arise out of the Roman empire and assume three (several) provinces. He will be different from the Romans, being an Edomite. He will attack the people of God and seek to change the law of God. He will be killed, and his dominion, maintained by the later Herods, will be removed and annihilated by AD 70, at which point the world will be given to the saints.

Thus, Herod is a type of Nero, his persecutions a type of Nero's. Herod the Great murdered the babies of Bethlehem. His successor beheaded John the Forerunner (compare Rv. 20:4). His successor, Herod Agrippa, put James to death and tried to put Peter to death (Acts 11). This last Herod died after speaking great boasts, playing God, and receiving worship. Compare the picture of Nero in Revelation 13. The destruction of the Herods is a promise of the destruction of Rome and of Nero.¹³

The scene of the vision now switches to heaven. Thrones are put in place. Then the Ancient of Days (God the Father) enters the courtroom and is seated on the fiery chariot-throne. Then the books are opened (verses 9,10).

Dan 7:

9 I watched till thrones were put in place, and the Ancient of Days was seated; His garment was white as snow, and the hair of His head was like pure wool. His throne was a fiery flame, its wheels a burning fire;

¹³ Jordan, James B. *Daniel*. Niceville, Florida: Biblical Horizons, 1994

The Visions of Daniel

10 A fiery stream issued and came forth from before Him. a thousand thousands ministered to Him; ten thousand times ten thousand stood before Him. The court was seated, and the books were opened (NKJV).

The scene then switches back to earth. As a result of the court judgment, the beast is slain and its body cast into the burning flame that was flowing from the throne (verse 11).

Dan 7:

11. I watched then because of the sound of the pompous words which the horn was speaking; I watched till the beast was slain, and its body destroyed and given to the burning flame (NKJV).

This corresponds to Revelation 19:20:

Then the beast was captured, and with him the false prophet who worked signs in his presence, by which he deceived those who received the mark of the beast and those who worshipped his image. These two were cast alive into the lake of fire burning with brimstone (NKJV).

The fire that Daniel saw proceeding from the throne of God has now become a lake in John's vision. John sees the same beast that Daniel saw. This same beast is "given to the burning flame" (Dan. 7:11). The rest of the beasts (Babylon, Persia, Greece) are not slain. Only their dominion is taken away and their lives are prolonged. This proves that Daniel is not seeing the end of the world. He is seeing the end of the Old Testament age and the beginning of God's kingdom. Daniel saw this as happening in the days of the Roman Empire. John said it was about to happen in his day (Rev 1:1). Nero, the beast incarnate, was destroyed in A.D. 68 when he committed suicide.¹⁴ Rome is the beast, but Nero is the personification of the beast.

¹⁴ Revelation was written during the reign of the sixth king. Of the seven heads (kings), it says, "Five have fallen, one is..." (Rev 17:10). Nero was number six. They were Julius, Augustus, Tiberius, Caligula, Claudius, Nero, and Galba.

The Visions of Daniel

The scene then switches to heaven again. He sees "One like the Son of Man" coming with the clouds to the Ancient of Days. He is then given His eternal kingdom (vs. 13,14).

Dan 7:

13 I was watching in the night visions, and behold, One like the Son of Man, coming with the clouds of heaven! He came to the Ancient of Days, and they brought Him near before Him.

14 Then to Him was given dominion and glory and a kingdom, that all peoples, nations, and languages should serve Him. His dominion is an everlasting dominion, which shall not pass away, and His kingdom the one which shall not be destroyed (NKJV).

Note that Daniel does not see the Son of Man coming to earth. He is ascending to the Father. The "coming" he sees is from a heavenly perspective as opposed to an earthly one. Jesus refers to the ascension in the following passages.

What then if you should see the Son of Man ascend where He was before (John 6:62 NKJV)?

Jesus said to her, "Do not cling to Me, for I have not yet ascended to My Father; but go to My brethren and say to them, 'I am ascending to My Father and your Father, and to My God and your God' " (John 20:17 NKJV).

Now when He had spoken these things, while they watched, He was taken up, and a cloud received Him out of their sight (Acts 1:9 NKJV).

It was about the time of the ascension of Christ that Daniel's vision was fulfilled. He received His kingdom in that generation. That is why He could say, "All power is given to me in heaven and in earth" (Mat. 28:18 NKJV).

In verse 16 Daniel asks for the interpretation of the vision and is told that the four beasts are four kingdoms that arise out of the earth. After that the saints would receive the kingdom. This took place at the ascension of Christ and is continuing eternally until Christ has put all enemies under His feet. When He came He put all the enemies at that time under His feet "having disarmed principalities and powers,

The Visions of Daniel

He made a public spectacle of them, triumphing over them in it (Col 2:15 NKJV).

And He will continue to reign until the rest are put under his feet. What He did in

A.D. 70 is a token and proof of what He will do in history to all nations.

Dan 7:

15 I Daniel was grieved in my spirit in the midst of *my* body, and the visions of my head troubled me.

16 I came near unto one of them that stood by, and asked him the truth of all this. So he told me, and made me know the interpretation of the things.

17 These great beasts, which are four, *are* four kings, *which* shall arise out of the earth.

18 But the saints of the most High shall take the kingdom, and possess the kingdom for ever, even for ever and ever.

19 Then I would know the truth of the fourth beast, which was diverse from all the others, exceeding dreadful, whose teeth *were of* iron, and his nails *of* brass; *which* devoured, brake in pieces, and stamped the residue with his feet;

20 And of the ten horns that *were* in his head, and *of* the other which came up, and before whom three fell; *even of* that horn that had eyes, and a mouth that spoke very great things, whose look *was* more stout than his fellows.

21 I beheld, and the same horn made war with the saints, and prevailed against them;

22 Until the Ancient of days came, and judgment was given to the saints of the most High; and the time came that the saints possessed the kingdom NKJV).

The interpretation then focuses on the little horn. He was to make war against the saints and overcome them until the time that the Ancient of Days would take His judgment seat on the throne. At that time a judgment would be made in favor of the saints. They would possess the kingdom. What kingdom? Obviously, it is the one that was to replace Caesar's (vs. 21,22).

Dan 7:

21 "I was watching; and the same horn was making war against the saints, and prevailing against them,

22 "until the Ancient of Days came, and a judgment was made *in favor* of the saints of the Most High, and the time came for the saints to possess the kingdom.

23 "Thus he said: "The fourth beast shall be A fourth kingdom on earth, Which shall be different from all *other* kingdoms, And shall devour the whole earth, Trample it and break it in pieces.

24 The ten horns *are* ten kings *Who* shall arise from this kingdom. And another shall rise after them; He shall be different from the first *ones*, And shall subdue three kings.

25 He shall speak *pompous* words against the Most High, Shall persecute the saints of the Most High, And shall intend to change times and law. Then *the saints* shall be given into his hand For a time and times and half a time.

The Visions of Daniel

26 'But the court shall be seated, And they shall take away his dominion, To consume and destroy *it* forever (NKJV).

Caesar changed the calendar (vs.25). He "... shall intend to change times and law." We still use that calendar today. July is named for Julius and August is named for Augustus.

Then the saints shall be given into his hand for a time and times and half a time (vs.25 NKJV).

Concerning the meaning of "time and times and half a time" let us consider some of the commentaries. Matthew Henry, Clark, and Gill favor the "year-day" theory. They say that a "time" stands for a year, and half a time as half a year, but then go on to say that a prophetic year of 360 days stands for 360 years. They interpret the little horn as popish Rome that ruled the church for 1260 years. The Adventists do the same. The Geneva Commentary simply says, "a long time, the time and times..."

Jamieson, Fausset, and Brown give us their interpretation below.

time ... times and ... dividing of time--one year, two years, and half a year:1260 days (Re 12:6,14); forty-two months (Re 11:2,3). That literally three and a half years are to be the term of Antichrist's persecution is favored by Dan 4:16,23, where the year-day theory would be impossible... Compare Nu 14:34, where a year of wandering in the wilderness was appointed for each day of the forty during which the spies searched Canaan; but the days were, in these two cases, merely the type or reason for the years, which were *announced as they were to be fulfilled*. In the prophetic part of Nu 14:34 "years" are literal. If the year-day system were applied to them, they would be 14,400 years! In Eze 4:4-6, if *day* meant *year*, Ezekiel would have lain on his right side forty years! The context here in Dan 7:24,25, is not symbolical. Antichrist is no longer called a horn, but a *king* subduing three out of ten *kings* (no longer horns, Dan 7:7,8). So in Da 12:7, where "time, times, and half a time," again occurs, nothing symbolic occurs in the context. So that there is no reason why the three and a half years should be so. For the first four centuries the "days" were interpreted literally; a mystical meaning of the 1260 days then began. WALTER BRUTE first suggested the year-day theory in the end of the fourteenth century.¹⁵

¹⁵ <http://eword.gospelcom.net/comments/>

The Visions of Daniel

A time is one year. Times is two years. Half a time is half a year. That makes three and a half years. This is exactly how long Nero persecuted the church. For a three and a half year period between¹⁶ A.D. 64 to 68 he slaughtered thousands of Christians in Rome. He killed both Peter and Paul at this time. Daniel saw it over 600 years beforehand. No wonder that he said, "I, Daniel, was grieved in my spirit" (vs. 15).

Dan 7:

26 But the court shall be seated, and they shall take away his dominion, to consume and destroy it forever.

27 Then the kingdom and dominion, and the greatness of the kingdoms under the whole heaven, shall be given to the people, the saints of the Most High. His kingdom is an everlasting kingdom, and all dominions shall serve and obey Him (NKJV).

28 This *is* the end of the account. As for me, Daniel, my thoughts greatly troubled me, and my countenance changed; but I kept the matter in my heart.

Nero's dominion was taken away by A.D. 70. All dominions are not yet serving and obeying Christ, but the day is not yet over.

The kingdoms of this world have become *the kingdoms* of our Lord and of His Christ, and He shall reign forever and ever! (Rev 11:15 NKJV).

For the earth will be filled with the knowledge of the glory of the LORD, as the waters cover the sea (Hab 2:14 NKJV).

All the ends of the world shall remember and turn to the LORD, And all the families of the nations shall worship before You (Ps 22:27 NKJV).

The judgment was made when the court was seated. The court was seated when the Ancient of Days was seated on the Great White Throne and the Son of Man ascended. Just because a judgment is made does not mean that it is obeyed immediately. Sometimes there must be follow-up procedures and enforcement. That is what has been happening since then.

¹⁶ David Chilton says, "Whereas *seven* is used to represent wholeness and completion, *three and a half* appears to be a *broken seven*: sadness, death, and destruction ..." (*Days of Vengeance*. Dominion Press, Tyler, Tx. 1987.) The word seven in Hebrew means oath, and is synonymous with covenant.

The Visions of Daniel

For He must reign till He has put all enemies under His feet (1 Cor. 15:25 NKJV).

His reign began when He ascended. By A.D. 70, He had destroyed the beast and Jerusalem. He *now* rules with a rod of iron.

For David did not ascend into the heavens, but he says himself: 'The Lord said to my Lord, "Sit at My right hand, till I make Your enemies Your footstool."' Therefore let all the house of Israel know assuredly that God has made this Jesus, whom you crucified, both Lord and Christ (Acts 2:24,35,36 NKJV).

Christ sat down at the right hand of God when He ascended to the Father.

Now He is in the process of making His enemies His footstool.

For the nation and kingdom which will not serve you shall perish, and those nations shall be utterly ruined (Isa. 60:12 NKJV).

This means that He will not rest until all nations change their laws to conform to the law that goes forth from Zion and submit to the King. Not until that happens will the last enemy (death) be destroyed in history.¹⁷

Thrones Were Put In Place

I watched till thrones were put in place, and the Ancient of Days was seated... (Dan 7:9 NKJV).

But the court shall be seated ... (Dan 7:26 NKJV).

The seating of the thrones and the court happens at the time that the Ancient of Days is seated and the Son of Man comes (ascends to Him). Not only is the Ancient of Days seated, but there are other thrones, also. It is true that there was a gap of forty years between the ascension and the coming in A.D. 70, but it was still during this New Testament period. His coming in A.D. 70 was not a coming in the

¹⁷ It is true that Christ destroyed death at Calvary. Death is destroyed for the saints when we are raised after death. But it will also be destroyed in history at the final coming of Christ.

The Visions of Daniel

flesh. It was the same type of coming that occurred many times in Old Testament days.¹⁸

The burden against Egypt. Behold, the LORD rides on a swift cloud, And will come into Egypt (Isaiah 19:1 NKJV).

This reference to the thrones being put in place corresponds to the New Testament fulfillment as shown in the following verse.

[E]ven when we were dead in trespasses, made us alive together with Christ (by grace you have been saved), and raised us up together, and made us sit together in the heavenly places in Christ Jesus. (EPH 2:5,6)

This ascension of the saints is also depicted in the vision language of John in Revelation 20. He has made us kings and priests (Rev. 1:6).

And I saw thrones, and they sat on them, and judgment was committed to them. And I saw the souls of those who had been beheaded for their witness to Jesus and for the word of God, who had not worshipped the beast or his image, and had not received his mark on their foreheads or on their hands. And they lived and reigned with Christ for a thousand years. But the rest of the dead did not live again until the thousand years were finished. This is the first resurrection (Rev 20:4,5 NKJV).

The first resurrection is when we are born again (according to Ephesians 2:1). The second is the resurrection of the body. Our souls were beheaded when we lost the headship of Adam (See Augustine's *City of God*, Chapters 6-9). We refuse to worship the image of the beast (Caesar or the state). We do this by saying that we have another king to whom Caesar (the state) must bow. Instead of the mark of the beast, we bear the seal of God in our foreheads because we sigh and weep over all the sin in Jerusalem.

The LORD said to him, "Go through the midst of the city, through the midst of Jerusalem, and put a mark on the foreheads of the men who sigh and cry over all the abominations that are done within it" (Ezek 9:4 NKJV).

¹⁸ See 2 Sam 22:10; Gen 11: 5; Gen 18:14; Exo 3: 8; 4:31;19:11; 19:20; Num 11:17; Num 11:25; Isa 13:5; Isa 31:4b.

The Visions of Daniel

The Books Were Opened

Daniel saw the seating of the Ancient of Days and "the books were opened"

(vs. 10). John also saw the same scene in Revelation 20:11.

Then I saw a great white throne and Him who sat on it, from whose face the earth and the heaven fled away. And there was found no place for them. And I saw the dead, small and great, standing before God, and books were opened. And another book was opened, which is the Book of Life. And the dead were judged according to their works, by the things which were written in the books (Rev 20:11,12 NKJV).

This judgment in Revelation 20 appears to be the same as in Daniel 7. The Ancient of Days came, and a judgment was made. According to verses 10 and 11, this was to happen in the days of the little horn (Nero).

The court was seated, And the books were opened. I watched then because of the sound of the pompous words which the horn was speaking (Dan 7:10,11 NKJV).

The Son of Man Coming

I was watching in the night visions, and behold, One like the Son of Man, coming with the clouds of heaven! He came to the Ancient of Days, and they brought Him near before Him (Dan 7:13 NKJV).

The phrase, "Son of Man coming with the clouds," is found for the first time in Daniel. It is found in no other Old Testament passage. Every time this phrase is mentioned in the New Testament, it is referring to Daniel 7. In Daniel 7, He is not coming to earth. He is ascending to the Ancient of Days to receive His kingdom. That is His "coming." Also, through that sign, coming with the armies of heaven to destroy Jerusalem, He was seen coming to the Ancient of Days. When He destroyed Jerusalem, every eye saw Him coming with the clouds to the Ancient of Days.

Let us examine carefully each time this idea is mentioned in the New Testament.

The Visions of Daniel

Then the sign of the Son of Man will appear in heaven, and then all the tribes of the earth will mourn, and they will see the Son of Man coming on the clouds of heaven with power and great glory (Mat 24:30 NKJV).

Jesus said to him, "It is as you said. Nevertheless, I say to you, hereafter you will see the Son of Man sitting at the right hand of the Power, and coming on the clouds of heaven" (Mat 26:64 NKJV).

And Jesus said, "I am. And you will see the Son of Man sitting at the right hand of the Power, and coming with the clouds of heaven" (Mar 14:62 NKJV).

And I looked, and behold, a white cloud, and on the cloud sat One like the Son of Man, having on His head a golden crown, and in His hand a sharp sickle (Rev 14:14 NKJV).

Now when He had spoken these things, while they watched, He was taken up, and a cloud received Him out of their sight (Acts 1:9 NKJV).

Assuredly, I say to you, there are some standing here who shall not taste death till they see the Son of Man coming in His kingdom (Mat 16:28 NKJV).

So then, after the Lord had spoken to them, He was received up into heaven, and sat down at the right hand of God (Mar 16:19 NKJV).

In each of the above New Testament passages, the Son of Man is not coming to earth, but to the Ancient of Days.

Behold, He is coming with clouds, and every eye will see Him, and they also who pierced Him (Rev 1:7 NKJV).

His disciples asked, "When shall these things be, and what will be the sign of your coming and of the end of the age" (Mat. 24:3 NKJV)? He goes on to tell them of the destruction of Jerusalem and the signs that would precede it. The way the Son of Man could be seen coming was through the sign. The sign was the destruction of Jerusalem. Every eye saw that. That was the sign that He had come. It signaled the end of the Old Testament age. It was the sign of His coming and the end of the age. The only age they knew of was the one they were then living in. It was the Old Testament age. He then told them when those things would be. He said it would happen in that generation (Mat 24:34). He said these things in A.D. 30. His word

The Visions of Daniel

was fulfilled 40 years later in A.D. 70. It is very important to see that Daniel said this was all fulfilled at the time of the fourth beast.

The Visions of Daniel

CHAPTER THREE Daniel Chapter 8

1 In the third year of the reign of King Belshazzar a vision appeared *to me--to me*, Daniel--after the one that appeared to me the first time.

2 I saw in the vision, and it so happened while I was looking, that I *was* in Shushan, the citadel, which *is* in the province of Elam; and I saw in the vision that I was by the River Ulai.

3 Then I lifted my eyes and saw, and there, standing beside the river, was a ram which had two horns, and the two horns were high; but one was higher than the other, and the higher one came up last. I saw the ram pushing westward, northward, and southward, so that no beast could withstand him; nor was there any that could deliver from his hand, but he did according to his will and became great (NKJV).

The Medo Persian Empire is presented as a bear in Chapter Seven and as the chest of silver in Chapter Two. But here it is envisioned as a ram with two horns. One horn being higher typified that Persia would be more prominent than the Medes.

Dan 8:

4 I saw the ram pushing westward, northward, and southward, so that no animal could withstand him; nor *was there any* that could deliver from his hand, but he did according to his will and became great.

5 And as I was considering, suddenly a male goat came from the west, across the surface of the whole earth, without touching the ground; and the goat had a notable horn between his eyes.

6 Then he came to the ram that had two horns, which I had seen standing beside the river, and ran at him with furious power.

7 And I saw him confronting the ram; he was moved with rage against him, attacked the ram, and broke his two horns. There was no power in the ram to withstand him, but he cast him down to the ground and trampled him; and there was no one that could deliver the ram from his hand (NKJV).

The Greek Empire, pictured in Chapter Seven as a Four-Headed Leopard and in Chapter Two as the belly of brass, is here portrayed as a swift He-Goat bounding furiously from the west, having one great horn, which, when broken, was replaced by Four horns.

The Visions of Daniel

Matthew Henry, Clark, John Gill, the Geneva Commentary and JFB all say the Great Horn was Alexander the Great, who broke the Persian Empire in 331 BC. This prophecy was written in 550 BC, 200 years before its fulfillment.

Dan 8:

8 Therefore the male goat grew very great; but when he became strong, the large horn was broken, and in place of it four notable ones came up toward the four winds of heaven (NKJV).

The Four Horns, in Chapter 8:21-22, and the Four Heads of 7:6, were the Four Kingdoms into which Alexander's Empire was divided after he died. He conquered the world by the age of 30 and died at the age of 33. His empire spread Greek culture over the entire world. It was then divided between his four generals. The two major divisions of his kingdom dealt with by Daniel were Syria (the North), and Egypt (the South).

Dan 8:

9 And out of one of them came a little horn which grew exceedingly great toward the south, toward the east, and toward the Glorious Land (NKJV).

The Little Horn, which arose out of one of the Four, is thought by the Geneva Commentary, Gill and many others to mean Antiochus Epiphanes, 175-164 BC, of the Syrian branch of the Greek Empire, who made a determined effort to stamp out the Jewish religion. The repeated phrase, "time of the end," refers to the approaching end of the Old Testament Age or simply to "the future." See below how the phrase was used in other passages.

When Jacob called his sons together just before he died, he prophesied over each one of them, and told what would befall each tribe. He said, "Gather together that I may tell you what shall befall you in the last days" (Gen. 49:1 NKJV). For example, Jacob prophesies, "Zebulun shall dwell by the haven of the sea; he shall

The Visions of Daniel

become a haven for ships, and his border shall adjoin Sidon" (Gen. 49:13 NKJV). This prophecy was fulfilled in Old Testament times, and was called "the last days." When modern people read this terminology in the Bible, we are sometimes so vain as to suppose that it is talking about our days. As the song says, "You're so vain. You probably think this song is all about you." The term, "latter days," or "last days" simply means later days. It means, "the future." It did not mean *our* future. It meant *their* future.

Dan 8:

10 And it grew up to the host of heaven; and it cast down some of the host and some of the stars to the ground, and trampled them (NKJV).

The little horn grows up to the host of heaven and casts down stars. This means that Antiochus Epiphanes would depose rulers in a tyrannical way.

Dan 8:

11 He even exalted himself as high as the Prince of the host; and by him the daily sacrifices were taken away, and the place of His sanctuary was cast down (NKJV).

The prince of the host was the high priest. Antiochus put an end to the dynasty of high priests that descended from Zadoc. He also put an idol of his god in the Temple. That is the sense in which the place of the prince's sanctuary was cast down.

Dan 8:

12 Because of transgression, an army was given over to the horn to oppose the daily sacrifices; and he cast truth down to the ground. He did all this and prospered (NKJV).

It says the reason God allowed Antiochus to do this was because of the transgression of God's people. As a judgment sent from God, Antiochus sacrificed a pig on the altar and tried to stamp out Judaism. He forced the Jews to offer sacrifices to the Greek god. He forbade the circumcision of their children. It was at this time

The Visions of Daniel

that the family of the Maccabees arose in rebellion. They fled to the wilderness, gathered a small army and after three years recovered the Temple.

Dan 8:

13 Then I heard a holy one speaking; and another holy one said to that certain one who was speaking, "How long will the vision be, concerning the daily sacrifices and the transgression of desolation, the giving of both the sanctuary and the host to be trampled under foot?" And he said to me, "For two thousand three hundred days; then the sanctuary shall be cleansed" (NKJV).

2300 days is about six years. Antiochus first polluted the Temple and stole some of the holy vessels. Three years later he put the idol there and sacrificed a pig on the altar. The Temple remained desolate for three years after that. The total time was about six years from the time he stole the holy vessels (2300 days). All this was told to Daniel 375 years beforehand.

Dan 8:

14 And he said to me, "For two thousand three hundred days; then the sanctuary shall be cleansed."

15 Then it happened, when I, Daniel, had seen the vision and was seeking the meaning, that suddenly there stood before me one having the appearance of a man.

16 And I heard a man's voice between *the banks of* the Ulai, who called, and said, "Gabriel, make this *man* understand the vision."

17 So he came near where I stood, and when he came I was afraid and fell on my face; but he said to me, "Understand, son of man, that the vision *refers* to the time of the end."

18 Now, as he was speaking with me, I was in a deep sleep with my face to the ground; but he touched me, and stood me upright.

19 And he said, "Look, I am making known to you what shall happen in the latter time of the indignation; for at the appointed time the end *shall be*."

20 "The ram which you saw, having the two horns--*they are* the kings of Media and Persia.

21 "And the male goat *is* the kingdom of Greece. The large horn that *is* between its eyes *is* the first king.

22 "As for the broken *horn* and the four that stood up in its place, four kingdoms shall arise out of that nation, but not with its power (NKJV).

Gabriel tells Daniel that the vision refers to the time of the end (v. 17). He then proceeds to clarify which end by describing the four kingdoms that would arise from Alexander's kingdom. This "end" must refer to the end of these four Greek

The Visions of Daniel

kingdoms. This whole vision refers to the filling up of the cup of wrath. Verse 19 says, "I am making known to you what shall happen in the latter time of the indignation; for at the appointed time the end shall be" (NKJV). In Genesis, it took four hundred years for the sins of the Amorites to fill the cup of wrath. God told Abraham that his people would go down to Egypt for four hundred years because the iniquity of the Amorites (the inhabitants of Palestine) was not yet full (Gen. 15:16). In Daniel's case, the iniquity of the Jews was not yet full. It would take another 620 years from the time Daniel had this vision. The cup got full in A.D. 70 when Jerusalem was destroyed. Jesus said, "Fill up, then, the measure of your fathers' guilt. Serpents, brood of vipers! How can you escape the condemnation of hell? Therefore, indeed, I send you prophets, wise men, and scribes: some of them you will kill and crucify, and some of them you will scourge in your synagogues and persecute from city to city, that on you may come all the righteous blood shed on the earth, from the blood of righteous Abel to the blood of Zechariah, son of Berechiah, whom you murdered between the Temple and the altar. Assuredly, I say to you, all these things will come upon this generation" (Mat. 23:32-36 NKJV).

Paul said, "wrath has come upon them to the uttermost" (1 Thess 2:16 NKJV).

Then, we see the seven cups of wrath being poured out on Jerusalem (the whore of Babylon) in Revelation.

Then I saw another sign in heaven, great and marvelous: seven angels having the seven last plagues, for in them the wrath of God is complete [full] (Rev 15:1 NKJV).

And great Babylon was remembered before God, to give her the cup of the wine of the fierceness of His wrath (Rev 16:19 NKJV).

And who is this "great Babylon?" Neither literal Babylon, Nineveh, Egypt, nor Rome had killed the prophets. The key to that riddle is found in Rev 18:24 where

The Visions of Daniel

it says, "In her was found the blood of prophets and saints" (NKJV). Had Rome yet been guilty of that? No. Had literal Babylon? No. Then who? Jesus answers that one when He says, "O Jerusalem, Jerusalem, the one who kills the prophets ..." (Mat. 23:37 NKJV). Isaiah answers it when he says, "How the faithful city [Jerusalem] has become a harlot" (Isa. 1:21 NKJV). If the shoe fits, wear it.

Gabriel goes on to interpret the vision.

Dan 8:

23 And in the latter time of their kingdom, when the transgressors have reached their fullness, a king shall arise, having fierce features, Who understands sinister schemes.

24 His power shall be mighty, but not by his own power; he shall destroy fearfully, and shall prosper and thrive; he shall destroy the mighty, and also the holy people.

25 Through his cunning he shall cause deceit to prosper under his hand; and he shall magnify himself in his heart. He shall destroy many in their prosperity. He shall even rise against the Prince of princes; but he shall be broken without human hand (NKJV).

When the "transgressors reached their fullness" Antiochus Epiphanes arose. They had not reached their fullness to the uttermost. But in a relative sense they had reached a fullness that required the pouring out of the wrath of God by bringing this desolation to the Temple. John Gill, Matthew Henry, Geneva, and JFB say Antiochus Epiphanes is the little horn of this chapter. He is not to be confused with the little horn of Chapter Seven. The one in Chapter Seven arose out of the fourth beast. The one in Chapter Eight came out of the third beast.

Antiochus was "broken without human hand." That means that he was to die by the hand of God. He died of a disease. It can be read about in 1 Maccabees.

Dan 8:

26 And the vision of the evenings and mornings which was told is true; therefore seal up the vision, for it refers to many days in the future (NKJV).

To "seal up the vision" means that it would not be understood fully until it had been somehow unsealed by God. This is what we see the Lamb doing in Revelation.

The Visions of Daniel

The veil was rent by Christ. The mystery that had been hidden from the ages was now revealed (Rom 16:25).

It says, "It refers to many days in the future." Some say that "soon" does not mean the same to God as it does to us. Here Gabriel says the vision was to be sealed because it refers to many days in the future. Here we find the key to how God uses time prophecies. This vision of Antiochus Epiphanes was not fulfilled for at least 375 years. This shows us what "many days" means to God. If "many days in the future" means 375 years, then "soon" must mean at least something less than 375 years. This shows us that when the Revelation of John was to take place soon, then it had to take place in a period of time less than 375 years. Actually, Jesus said it would take place in that generation (Mat. 24:34 & 23:36). One minister said that "soon" means nothing to God. Why would God tell us something is going to happen soon if soon meant nothing? Does this not smack of making the word of God of none effect? Even if soon means nothing to God, it surely means something to us when God says it. If it means nothing, then why say it?

First of all, God is not the one speaking here. It is *Gabriel* who says this is for many days in the future. In Revelation, it is either *John* or an *angel* that repeatedly say these "*things must shortly take place*" (Rev 1:1 NKJV). John is told the opposite of what Daniel is told. "And he said to me, 'Do not seal the words of the prophecy of this book, for the time is at hand'" (Rev 22:10 NKJV).

Daniel's prophecy of Chapter 8 was for many days in the future (375 years). John's prophecy was to take place shortly. John wrote during the days of the sixth king of Rome (Rev 17:10). The sixth Caesar was Nero. He died in A.D. 68, so John

The Visions of Daniel

must have written Revelation around A.D. 64-66. If it was all fulfilled by A.D. 70, that was soon.¹⁹ Kenneth Gentry lists eight pages of authors who advocate an early date for Revelation in *Before Jerusalem Fell*. (See appendix B for the list.)

For a thorough study on the date of Revelation, read *Before Jerusalem Fell* by Kenneth Gentry.

Dan 8:

27 And I, Daniel, fainted and was sick for days; afterward I arose and went about the king's business. I was astonished by the vision, but no one understood it (NKJV).

The word of God is not meant to always make us feel good. Though it might make us sick, it will never return void. It will always accomplish its purpose 100% of the time.

¹⁹ Kenneth Gentry gives strong evidence that Revelation was written before Jerusalem fell. He shows that the idea that it was written during the reign of Domitian comes from a single source. That source is Irenaeus. All others who say that quote him. The Syriac manuscripts and others say it was written during Nero's reign. Revelation was written during the reign of the sixth Caesar (of the seven heads on the beast). Revelation 17 says, "Five have fallen, one is." *Before Jerusalem Fell*. Tyler, Texas: The Institute for Christian Economics, 1989. Since the list of authors who subscribe to a later date all do it because of a single source, the author sees no need to list them. Irenaeus was written in Greek, but all we have is a Latin translation. And the whole issue depends on the translation of one word. When he said "it," meaning the Apocalypse was seen in the days of Domitian, it was possibly translated from the word "he," meaning John was seen. All others "parrot" Irenaeus.

The Visions of Daniel

CHAPTER FOUR Daniel Chapter 9

Daniel Nine opens with Daniel having read the prophecy of Jeremiah that after 70 years, God would cause the Jews to return to Jerusalem. This causes him to cry out to God to forgive their sins and fulfill His promise. Daniel is now in his seventieth year at Babylon. He came in 606 BC.

For thus says the LORD: After seventy years are completed at Babylon, I will visit you and perform My good word toward you, and cause you to return to this place (Jeremiah 29:1 NKJV).

Just because something is foreordained does not mean that we sit back and do nothing. God has also foreordained to use His people in bringing about His predestined purpose. The pattern after which we are to believe and pray is laid down clearly in Scripture. Daniel does not blame his oppressors for the slavery of his people; he blames his people for their sins. This is the pattern consistently laid out in the Bible. In the book of Judges, God sells His people into slavery every time they backslide. The solution is not to demonstrate against tyrants and play the “blame game;” the solution is to do what Daniel did and wait for God's time. God now offers every nation the opportunity to be His people.

Daniel cries out to God for forgiveness and to fulfill His promise to visit His people. Then an angel is sent with the prophecy of restoration. But the angel also predicts not just another seventy years, but also another seventy weeks of years determined to accomplish the coming of the Messiah and the destruction of Jerusalem. God is not only going to answer Daniel's prayer to forgive His people, He

The Visions of Daniel

is going to endure them seven times seventy. After that, there will be no remedy.

The end of the city and the sanctuary will be with a flood (9:26).

Dan 9:

1 In the first year of Darius the son of Ahasuerus, of the lineage of the Medes, who was made king over the realm of the Chaldeans--

2 in the first year of his reign I, Daniel, understood by the books the number of the years *specified* by the word of the LORD through Jeremiah the prophet, that He would accomplish seventy years in the desolations of Jerusalem.

3 Then I set my face toward the Lord God to make request by prayer and supplications, with fasting, sackcloth, and ashes.

4 And I prayed to the LORD my God, and made confession, and said, "O Lord, great and awesome God, who keeps His covenant and mercy with those who love Him, and with those who keep His commandments,

5 "we have sinned and committed iniquity, we have done wickedly and rebelled, even by departing from Your precepts and Your judgments.

6 "Neither have we heeded Your servants the prophets, who spoke in Your name to our kings and our princes, to our fathers and all the people of the land.

7 "O Lord, righteousness *belongs* to You, but to us shame of face, as *it is* this day--to the men of Judah, to the inhabitants of Jerusalem and all Israel, those near and those far off in all the countries to which You have driven them, because of the unfaithfulness which they have committed against You.

8 "O Lord, to us *belongs* shame of face, to our kings, our princes, and our fathers, because we have sinned against You.

9 "To the Lord our God *belong* mercy and forgiveness, though we have rebelled against Him.

10 "We have not obeyed the voice of the LORD our God, to walk in His laws, which He set before us by His servants the prophets.

11 "Yes, all Israel has transgressed Your law, and has departed so as not to obey Your voice; therefore the curse and the oath written in the Law of Moses the servant of God have been poured out on us, because we have sinned against Him.

12 "And He has confirmed His words, which He spoke against us and against our judges who judged us, by bringing upon us a great disaster; for under the whole heaven such has never been done as what has been done to Jerusalem.

13 "As *it is* written in the Law of Moses, all this disaster has come upon us; yet we have not made our prayer before the LORD our God, that we might turn from our iniquities and understand Your truth.

14 "Therefore the LORD has kept the disaster in mind, and brought it upon us; for the LORD our God *is* righteous in all the works which He does, though we have not obeyed His voice.

15 "And now, O Lord our God, who brought Your people out of the land of Egypt with a mighty hand, and made Yourself a name, as *it is* this day--we have sinned, we have done wickedly!

16 "O Lord, according to all Your righteousness, I pray, let Your anger and Your fury be turned away from Your city Jerusalem, Your holy mountain; because for our sins, and for the iniquities of our fathers, Jerusalem and Your people *are* a reproach to all *those* around us.

The Visions of Daniel

17 “Now therefore, our God, hear the prayer of Your servant, and his supplications, and for the Lord’s sake cause Your face to shine on Your sanctuary, which is desolate.

18 “O my God, incline Your ear and hear; open Your eyes and see our desolations, and the city which is called by Your name; for we do not present our supplications before You because of our righteous deeds, but because of Your great mercies.

19* “O Lord, hear! O Lord, forgive! O Lord, listen and act! Do not delay for Your own sake, my God, for Your city and Your people are called by Your name.”

20 Now while I *was* speaking, praying, and confessing my sin and the sin of my people Israel, and presenting my supplication before the LORD my God for the holy mountain of my God,

21 yes, while I *was* speaking in prayer, the man Gabriel, whom I had seen in the vision at the beginning, being caused to fly swiftly, reached me about the time of the evening offering.

22 And he informed *me*, and talked with me, and said, “O Daniel, I have now come forth to give you skill to understand.

23 “At the beginning of your supplications the command went out, and I have come to tell *you*, for you *are* greatly beloved; therefore consider the matter, and understand the vision:

The Seventy Weeks

Dan 9:

24 Seventy weeks are determined for your people and for your holy city, to finish the transgression, to make an end of sins, to make reconciliation for iniquity, to bring in everlasting righteousness, to seal up vision and prophecy, and to anoint the Most Holy (NKJV).

Matthew Henry, JFB, Clark, Gill, and Geneva all agree that the seventy weeks are weeks of years. $7 \times 70 = 490$ years. The word “week” in Hebrew simply means “seven.” It does not mean seven days. It just means “seven.” Practically all commentators agree that the seventy weeks are weeks of years.²⁰

God is telling Daniel that just because the 70 years are complete does not mean that all the trouble is over. He here foretells the abomination of desolation (v. 27 below) and the destruction of Jerusalem at the end of the 70 sevens (490 years). God was going to endure the sins of Israel seven times seventy times. Sometime after that the cup of wrath would be full and would be poured out.

²⁰ Albert Barnes, Jamieson Faucett Brown, Wesley, Clark, and Gill all agree that the seventy weeks are weeks of years equaling 490 years.

The Visions of Daniel

Josephus tells us, "In the very same manner Daniel also wrote concerning the Roman government, and that our country should be made desolate by them."²¹ Joyce Baldwin tells us Josephus' "interpretation of the seventy sevens of Daniel became standard Jewish teaching, and passed into Christian exegesis."²²

The angel tells Daniel that during this period of 70 weeks (490 years), six things were to be accomplished. I shall use the translation of the *Jewish Study Bible*.

1. "...until the measure of transgression is filled." The cup would be filled to the uttermost.
2. "...and that of sin complete." God's wrath will complete it.
3. "...until iniquity is expiated." This happened at the cross.
4. "...and eternal righteousness ushered in." His kingdom came.
5. "...and prophetic vision ratified." It would be authoritatively sealed.
6. "...and the Holy of Holies anointed." The anointing of Jesus and the true Temple (the Church).

The sealing of vision and prophecy (Dan 9:24) could mean that the Canon would be completed, but probably means the same thing as it does in 8:26. It was sealed until it was fulfilled. That is, it was not understood until then. But in Revelation 22:10, John is told, "Do not seal up the words of the prophecy of this book, because the time is near" (NKJV). This proves that the prophecies of Revelation were fulfilled soon. In Revelation chapters four and five, the Lamb opens the seals and pours out the full cups of wrath.

Dan 9:

25 Know therefore and understand, that from the going forth of the command to restore and build Jerusalem until Messiah the Prince, there shall be seven weeks and sixty-two weeks; the street shall be built again, and the wall, even in troublesome times (NKJV).

Most learned men agree that the death of Christ happened at the passover in the month *Nisan*, in the *four thousand seven hundred and forty-sixth* year of the Julian

²¹ Jewish Antiquities X 276

²² Baldwin, Joyce G. *Daniel*. Downers Grove, Ill: Inter-Varsity Press, 1978. Baldwin cites ICC, p. 397, and says, "Among further details Montgomery refers to Jerome's information..."

The Visions of Daniel

period. *Four hundred and ninety* years, reckoned back from the above year, leads us directly to the month *Nisan* in the *four thousand two hundred and fifty-sixth* year of the same period; the very month and year in which *Ezra* had his commission from *Artaxerxes Longimanus*, king of Persia, (see [Ezr 7:9](#)), to restore and rebuild Jerusalem. See the commission in *Ezra*, [Ezr 7:11-26](#), and *Prideaux's Connexions*, vol. ii. p. 380.²³

The command to return to Jerusalem and permission to *rebuild the Temple* was given by Cyrus in 536 BC.²⁴ The command to *restore Jerusalem* by Artaxerxes, the king of Persia at that time, took place seventy-nine years after the decree of Cyrus in the time of Nehemiah. The Temple was rebuilt in the days of Cyrus, but then Nehemiah rebuilt the walls of Jerusalem at the command of Artaxerxes in 457 BC. The period is divided into seven weeks and sixty-two weeks. After seven weeks the street and wall would be rebuilt. After another sixty-two weeks, Messiah would come. There are 69 weeks of years ($7+62 = 69$) from that date to the beginning of Christ's ministry (A.D. 26). (Christ was born 6 BC - 4 BC and began His ministry at age 30 in A.D. 26.) Sixty nine times seven equals 483. We also see that 457 plus 26 equals 483.

Dan 9:

26 And after the sixty-two weeks Messiah shall be cut off, but not for Himself; and the people of the prince who is to come shall destroy the city and the sanctuary. the end of it shall be with a flood, And till the end of the war desolations are determined (NKJV).

It does not say that Messiah would be cut off immediately at the end of 69 weeks. It just says, "after" the end of the seven plus sixty-two weeks it would happen. The end of the 69 weeks (483 years) brings us to A.D. 26. Christ was crucified three and a half years after that. Nor does it say that the city and Temple

²³ Clark's Commentary

²⁴ James Jordon says that the dates we have are inaccurate because Alexander destroyed the Persian records, and that Cyrus, himself, gave the command to restore Jerusalem in 457 BC. (*Daniel*. Niceville, Florida: Biblical Horizons, 1994.) If this is true, then these numbers make no sense.

The Visions of Daniel

would be destroyed immediately at the end of the sixty-two weeks. The clear meaning was still sealed (hidden). Now that it has been fulfilled, we can see what the angel meant. Messiah was cut off three and a half years after the end of the 69th week, and the Temple was destroyed forty years after the crucifixion. The end of it came with a flood of desolation.

That leaves one week - the 70th.

Dan 9:

27 And he shall confirm the covenant with many for one week: and in the midst of the week he shall cause the sacrifice and the oblation to cease, and for the overspreading of abominations he shall make *it* desolate, even until the consummation, and that determined shall be poured upon the desolate (KJV).

John Calvin and Mathew Henry interpret verse 27 in the following manner.

At the beginning of the seventieth week (A.D. 26) Christ made a covenant with many for that week, but was cut off in the middle of it (after 3 1/2 years of ministry) in A.D. 30. That caused an end to the ceremonial sacrifices of the Temple, because His blood is the only blood that can truly wash away sin. All of this was foretold 565 years beforehand!

Over the centuries, the great commentators have agreed that Christ is the One who confirmed the covenant with many (see Matthew Henry, Matthew Poole, Adam Clarke, Jamieson Fausset and Brown, Edward Young, John Calvin, John Wesley, Geneva Study Bible, etc), The Church Fathers such as Tertullian, Clement of Alexandria, Origen, Athanasius, Augustine, and Eusebius regarded the 70th week of Daniel as having already been fulfilled by Christ's earthly ministry, as did the Venerable Bede, John Wycliffe, Luther, Melancthon, John Gill, etc.²⁵

Christ is the one who caused the desolation of Jerusalem in A.D. 70. It says it was because of "the overspreading of abominations he shall make *it* desolate." Christ is the one who poured out the cup of wrath on the Temple when the cup got full in

²⁵ Williamson, Thomas. *Essays In Old Testament Prophecy*: Thomas Williamson, 3131 S. Archer Ave., Chicago, Ill. 60608, 2006.

The Visions of Daniel

A.D. 70. The "consummation" refers to the "fullness" of the cup. The "desolate" is Jerusalem and the Temple. The expression, "abomination of desolation" is used two times in Daniel. In 11:31 it refers to what Antiochus IV would do; in 12:11 it refers to what Rome would do in A.D. 70, and is quoted by Jesus in Matthew 24:15. He also says that it would take place in His generation (Mat 24:34).

Therefore when you see the "abomination of desolation," spoken of by Daniel the prophet, standing in the holy place (whoever reads, let him understand), then let those who are in Judea flee to the mountains. ...For then there will be great tribulation, such as has not been since the beginning of the world until this time, no, nor ever shall be" (Mat. 24:15-21 NKJV).

Luke quotes Jesus also. But instead of using the word, "abomination of desolation," He says, "Jerusalem surrounded by armies."

But when you see Jerusalem surrounded by armies, then know that its desolation is near. Then let those in Judea flee to the mountains, let those who are in the midst of her depart, and let not those who are in the country enter her (Luke 21:20,21 NKJV).

Here we see how Jesus interpreted Daniel. Both Daniel and Matthew wrote in the same language that Jesus used (Aramaic). Luke translates it into Greek and tells us what "abomination of desolation" means. It means, "Jerusalem surrounded by armies." The Roman armies made it desolate.

Jesus goes on to say that all these things would be fulfilled in that generation (Mat. 24:34). Luke says it this way: "For these are the days of vengeance, that all things which are written may be fulfilled" (Luke 21:22 NKJV). All things that were written were fulfilled in A.D. 70. That is, all things concerning Jerusalem and the Temple. This includes the Law that had to do with that land and that Temple. The ceremonial law became obsolete (Heb 8:13). The spirit of the moral and civil law are now being fulfilled during the age of the Messiah. The law now proceeds from the New Jerusalem.

The Visions of Daniel

For out of Zion the law shall go forth, and the word of the LORD from Jerusalem (Micah 4:2 NKJV).

Now let us go back to verse 26 of Daniel Nine, which says, "The people of the prince who is to come shall destroy the city and the sanctuary." Who are these people and their prince? Some say the prince was Titus, the Roman general, but Commentator Matthew Henry says that the prince is Christ and the people were the Roman army.

It is here foretold that the people of the prince that shall come shall be the instruments of this destruction, that is, the Roman armies, belonging to a monarchy yet to come (Christ is the prince that shall come, and they are employed by him in this service; they are his armies, Matt 22:7), or the Gentiles (who, though now strangers, shall become the people of the Messiah) shall destroy the Jews.²⁶

Even Titus said, "Surely God was with us in this war, who brought the Jews down from these strongholds, for what could hand or engine do against these towers" (Josephus, W VI, 403)?

This interpretation makes sense because "Messiah the prince" is the subject starting in verse 25. He was the prince to come. All armies belong to Him. The term "LORD of Hosts," can be translated, "LORD of the armies." It is translated that way in Spanish.

Know therefore and understand, that from the going forth of the command to restore and build Jerusalem until **Messiah the Prince**, there shall be seven weeks and sixty-two weeks; the street shall be built again, and the wall, even in troublesome times. And after the sixty-two weeks Messiah shall be cut off, but not for Himself; and the people of **the prince** who is to come shall destroy the city and the sanctuary. The end of it shall be with a flood, And till the end of the war desolations are determined. Then **He** shall confirm a covenant with many for one week; but in the middle of the week **He** shall bring an end to sacrifice and offering, and on the wing of abominations shall be one who makes desolate, even until the consummation, which is determined, is poured out on the desolate (Dan 9:25-27 NKJV emphasis added).

²⁶ Mathew Henry's Commentary on Daniel 9.

The Visions of Daniel

Many scholars (Clark, Geneva, Gill, and Henry)²⁷ believe that the “prince who is to come” refers to Titus, the Roman general who destroyed Jerusalem, but Titus did not confirm a covenant for one week. It seems more likely to the author that Christ is that prince, and His people are the real destroyers of Jerusalem. Messiah the Prince is the subject in verses 25-27 and no other “prince” is mentioned. He is the one who brings an end to sacrifice and offering, and the one who makes Jerusalem desolate. He is the same prince of the people who were to destroy Jerusalem. This goes along with Revelation 19 where the armies of heaven follow Him to destroy Jerusalem. (Do not be confused by the lack of the capital letter of "prince" in some versions. There are no capital letters in the original language.) Christ, the Prince, sent out His armies and destroyed those murderers. This was predicted in the following passages.

They come from a far country, From the end of heaven-- The LORD and His weapons of indignation, To destroy the whole land (Isa 13:5 NKJV).

In the above verse from Isaiah, God comes from the end of heaven (from over the horizon) to destroy the whole land? He was to come with Babylon to destroy Jerusalem the first time it was destroyed.

But when the king heard about it, he was furious. And he sent out his armies, destroyed those murderers, and burned up their city (Mat 22:7 NKJV).

Was not Jesus predicting in the above verse what God would do to Jerusalem? He sent out the Romans along with His angels to destroy it. He is truly the “LORD of Hosts.” He is over both light and darkness. His armies consist of men, angels, and demons. How else can the following Scriptures be explained?

²⁷ Gill also says, “some understand this of Messiah the Prince that should come in his power, and in a way of judgment upon the Jewish nation, and destroy them for their rejection of him; whose people the Romans would be...”

The Visions of Daniel

I form the light, and create darkness: I make peace, and create evil: I the LORD do all these *things* (Isa 45:7 KJV).

Now there was a day when the sons of God came to present themselves before the LORD, and Satan came also among them (Job 1:6NKJV).

And the LORD said unto him, Wherewith? And he said, I will go forth, and I will be a lying spirit in the mouth of all his prophets. And he said, Thou shalt persuade *him*, and prevail also: go forth, and do so (1 Kings 22:22 NKJV).

The Consummation

Daniel 9:27 speaks of “the consummation, which is determined” (NKJV).

Hebrews 9:26 tells us that the “consummation of the ages” took place during New Testament times.

Now once at the consummation of the ages He has been manifested to put away sin by the sacrifice of Himself (NAS95).

Jesus said, “The time is fulfilled, and the kingdom of God is at hand. Repent, and believe in the gospel” (Mark 1:5 NKJV). Can it be denied that the Old Testament age ended (was consummated) when the Temple was destroyed? Is this not what Paul referred to when he said, “For if what is passing away *was* glorious, what remains *is* much more glorious” (2Cor 3:11)?

Gill speculates that perhaps the Romans made a seven-year covenant with the nations. JFB (Jamieson, Fauset, and Brown), Matthew Henry, Albert Barnes, Wesley, and the Geneva Commentary say that Christ is the one who confirmed the covenant.

He shall confirm the covenant--Christ. The confirmation of the covenant is assigned to Him also elsewhere. Isa 42:6, "I will give thee for a *covenant* of the people" (that is, He in whom the covenant between Israel and God is personally expressed); compare Lu 22:20, "The new testament in My blood"; Mal 3:1, "the angel of the covenant"; Jer 31:31-34, describes the Messianic covenant in full. Contrast Da 11:30,32, "forsake the covenant," "do wickedly against the covenant."²⁸

Summary of Daniel's Seventy Weeks

²⁸ JFB <http://eword.gospelcom.net/comments/daniel/jfb/daniel9.htm>

The Visions of Daniel

Christ was born 6 BC to 4 BC. He was crucified in A.D. 30, at age 33. The 70 weeks began in 457 BC and ended 490 years later in A.D. 33 ($457 + 33 = 490$). The first 69 weeks were divided into two parts - 7 weeks, and 62 weeks. The city was rebuilt after 7 weeks (49 years). After another 62 weeks, Christ was cut off after A.D. 26. $69 \times 7 = 483$. The command to rebuild was in 457 BC. Add A.D. 26 to that and you have the year Messiah started His ministry. $457 + 26 = 483$.

That leaves one week (7 years). He made a covenant at the outset of the seventieth week (the last 7 year period) when He commenced His ministry and proclaimed that the "acceptable year of the Lord" had arrived (See Luke 4:18ff). But after 3 1/2 years (the middle of the week) He caused the sacrifice and offering of the Temple to cease by becoming the true sacrifice.

Daniel's 70 Weeks & Time of the End Time Line

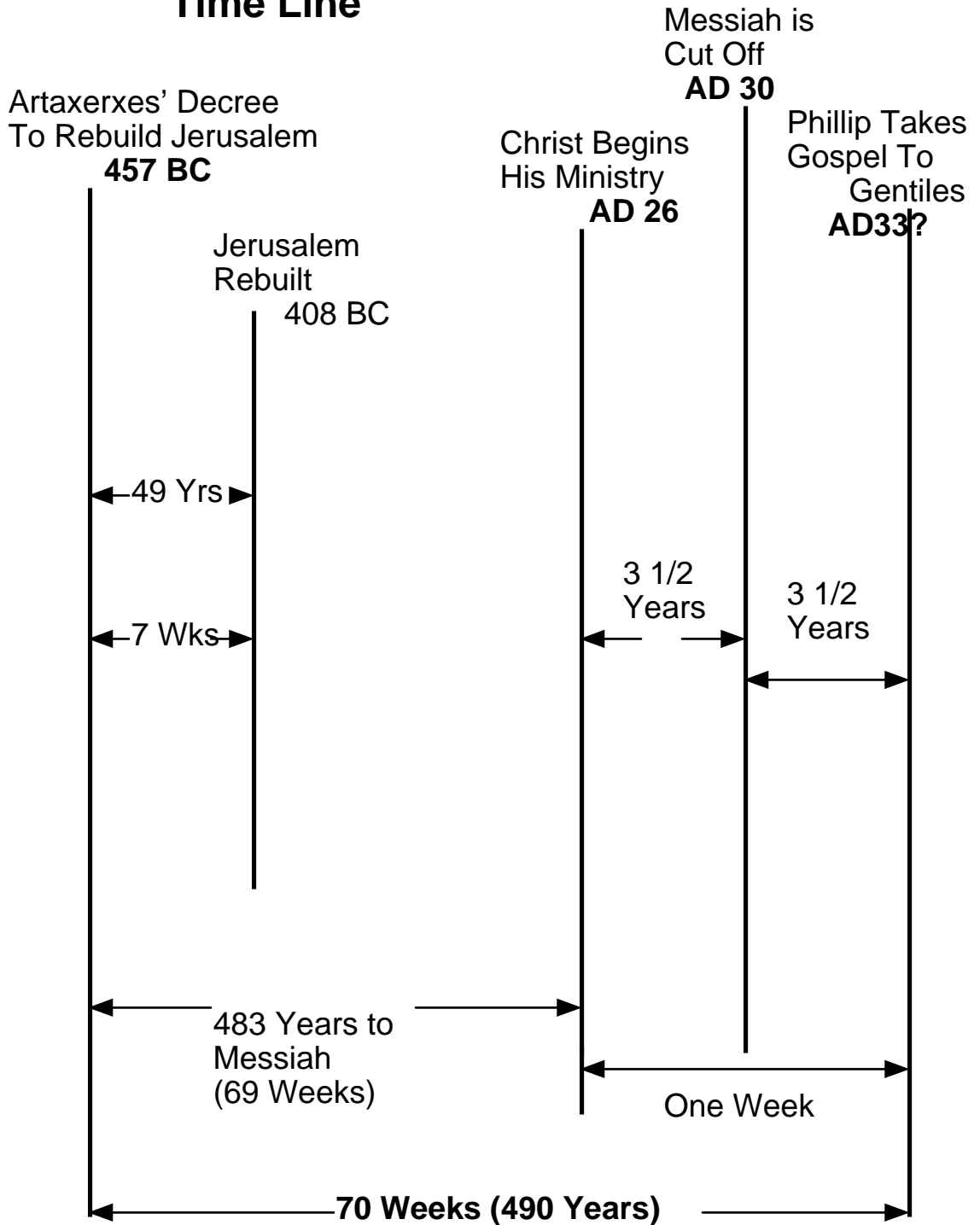

The Visions of Daniel

CHAPTER FIVE Daniel Chapter 10

1 In the third year of Cyrus king of Persia a message was revealed to Daniel, whose name was called Belteshazzar. The message *was* true, but the appointed time *was* long; and he understood the message, and had understanding of the vision.

2 In those days I, Daniel, was mourning three full weeks.

3 I ate no pleasant food, no meat or wine came into my mouth, nor did I anoint myself at all, till three whole weeks were fulfilled.

4 Now on the twenty-fourth day of the first month, as I was by the side of the great river, that *is*, the Tigris,

5 I lifted my eyes and looked, and behold, a certain man clothed in linen, whose waist *was* girded with gold of Uphaz!

6 His body *was* like beryl, his face like the appearance of lightning, his eyes like torches of fire, his arms and feet like burnished bronze in color, and the sound of his words like the voice of a multitude (NKJV).

The vision that starts in Daniel Chapter Ten is the last vision of Daniel, and covers the next three chapters. It takes place in the third year of Cyrus. Daniel had been fasting and praying for three weeks when suddenly, while he is about his business by the river, Christ appears to him. The men with him do not see the vision, but the presence of God frightens them away, and Daniel is left alone in a trance on the ground. This is very similar to the appearance of Christ to Paul. The men with Paul "saw the light and were afraid, but they did not hear the voice of Him who spoke to me" (Acts 22:9 NKJV). Rushdoony also says this is an appearance of the pre-incarnate Christ.²⁹ The reason for this seeming to be the pre-incarnate Christ is because of the similarity to John's vision of Christ in Revelation Chapter One.

His feet were like fine brass, as if refined in a furnace, and His voice as the sound of many waters (Rev 1:15 NKJV).

²⁹ R.J. Rushdoony. *Thy Kingdom Come, Studies in Daniel and Revelation*. Vallecito, California: Ross House Books.

The Visions of Daniel

Dan 10:

7 And I, Daniel, alone saw the vision, for the men who were with me did not see the vision; but a great terror fell upon them, so that they fled to hide themselves.

8 Therefore I was left alone when I saw this great vision, and no strength remained in me; for my vigor was turned to frailty in me, and I retained no strength.

9 Yet I heard the sound of his words; and while I heard the sound of his words I was in a deep sleep on my face, with my face to the ground.

10 Suddenly, a hand touched me, which made me tremble on my knees and *on* the palms of my hands.

11 And he said to me, "O Daniel, man greatly beloved, understand the words that I speak to you, and stand upright, for I have now been sent to you." While he was speaking this word to me, I stood trembling.

12 Then he said to me, "Do not fear, Daniel, for from the first day that you set your heart to understand, and to humble yourself before your God, your words were heard; and I have come because of your words. But the prince of the kingdom of Persia withstood me twenty-one days; and behold, Michael, one of the chief princes, came to help me, for I had been left alone there with the kings of Persia (NKJV).

The prince of Persia is a Satanic principality (See Eph 6:12). Because God has put man over the earth, man gets the rulers he deserves. If man serves Satan, man gets Satan. This chapter illustrates that principalities are given territorial borders. Because men believe the lies of Satan, this gives Satan certain legal rights and authority over man.³⁰ That is the reason that Christ is subject to certain laws. They are the laws of God's nature. They said, "If you are the Christ, come down from the cross." He could have called for ten thousand angels, but He was obedient to the law of God and refused to use His power.

These principalities are under Satan, and Satan is under God. They rule because God put them there. God put them there because of man's sin. God is not in a war with Satan; the Church and the angels are. When men repent, they will automatically come down. We have no right to command principalities to come down. That is the sort of thing that Jude's mockers would do.

³⁰ Psalm 94:20 Shall the throne of iniquity, which devises evil by law, Have fellowship with You?

The Visions of Daniel

Likewise also these dreamers defile the flesh, reject authority, and speak evil of dignitaries. Yet Michael the archangel, in contending with the devil, when he disputed about the body of Moses, dared not bring against him a reviling accusation, but said, "The Lord rebuke you!" (Jude 1:8,9).

Daniel 10:

13 "But the prince of the kingdom of Persia withstood me twenty-one days; and behold, Michael, one of the chief princes, came to help me, for I had been left alone there with the kings of Persia (NKJV).

You will note that the vision he gives is about the kings that would come between 529 BC and A.D. 70. This prophecy would cover six hundred years. He calls that six hundred year period, the "latter days."

Daniel had fainted. The Lord strengthened him. He was so weak that he could not speak. In order for us to have understanding in the visions of the Lord, we need strength. Our weakness makes us faint and give up. Only God can give us that strength. Some say, "We just can't understand these things." But God says He will give us wisdom if we ask and believe (James 1:5 - 7).

Dan 10:

14 "Now I have come to make you understand what will happen to your people in the latter days, for the vision *refers to many days yet to come.*"

15 When he had spoken such words to me, I turned my face toward the ground and became speechless.

16 And suddenly, *one* having the likeness of the sons of men touched my lips; then I opened my mouth and spoke, saying to him who stood before me, "My lord, because of the vision my sorrows have overwhelmed me, and I have retained no strength.

17 "For how can this servant of my lord talk with you, my lord? As for me, no strength remains in me now, nor is any breath left in me."

18 Then again, *the one* having the likeness of a man touched me and strengthened me.

19 And he said, "O man greatly beloved, fear not! Peace *be* to you; be strong, yes, be strong!" So when he spoke to me I was strengthened, and said, "Let my lord speak, for you have strengthened me."

20 Then he said, "Do you know why I have come to you? And now I must return to fight with the prince of Persia; and when I have gone forth, indeed the prince of Greece will come. But I will tell you what is noted in the Scripture of Truth. (No one upholds me against these, except Michael your prince.

11:1 Also in the first year of Darius the Mede, I, even I, stood up to confirm and strengthen him.) (NKJV).

The Visions of Daniel

Christ confirmed and strengthened Darius the Mede. Some think that Darius is probably another name for Cyrus. But even if not, to strengthen Darius, the servant of Cyrus, is to strengthen Cyrus. Isaiah had prophesied the coming of Cyrus a hundred years beforehand, and God called him His “anointed” (Isa 45:1).

The Visions of Daniel

CHAPTER SIX Daniel Chapter 11

The prophecy of Daniel Eleven starts with the kings that would follow Cyrus, follows to Alexander the Great, then to the kings of Syria and Egypt. The author believes it then switches to Rome (11:36) and ends with the destruction of the Julio/Claudian line of Caesars during the Great Tribulation (A.D. 66-70). This was a period in which the cup of God's wrath was in the process of filling up. It continues and concludes in Chapter 12 with no gap of thousands of years and the pouring out of that cup during the 3 1/2 year Great Tribulation period (A.D. 66 to 70). The prophecy was given in 539 BC. To make it easier to follow, in this chapter I will indicate in bold letters when the Scripture text is given and how the likely historical fulfillment took place.

Dan 11:

2 And now I will tell you the truth: Behold, three more kings will arise in Persia, and the fourth shall be far richer than them all; by his strength, through his riches, he shall stir up all against the realm of Greece (NKJV).

Historical Fulfillment:

Cambyses was the first of the three kings after Cyrus (529 BC). Smerdis was the second. Darius Hystaspin was the third. Xerxes, the fourth king of Persia, attempted the invasion of Greece and was stopped by the Greeks.

Dan 11:

3 Then a mighty king shall arise, who shall rule with great dominion, and do according to his will (NKJV).

The Visions of Daniel

Historical Fulfillment:

Barnes, Henry, Gill, Clark, and Calvin say that Alexander the Great is the mighty king (331 BC) because the next verse says his kingdom would be “broken up and divided toward the four winds.”

Dan 11:

4 And when he has arisen, his kingdom shall be broken up and divided toward the four winds of heaven, but not among his posterity nor according to his dominion with which he ruled; for his kingdom shall be uprooted, even for others besides these (NKJV).

Historical Fulfillment:

As stated earlier, Alexander conquered the world by the time he was thirty, and died at age 33. His empire was then divided between his four generals. The two generals with whom we are concerned are Ptolemy of Egypt and Seleucus of Syria. Alexander had spread Greek culture over the entire empire. When Christ came in the fullness of time (the time that the cup of wrath was filling up), Greek was the universal language.

Dan 11:

5 Then the king of the South shall become strong, as well as one of his princes; and he shall gain power over him and have dominion. His dominion shall be a great dominion (NKJV).

Historical Fulfillment:

The king of the South is Ptolemy Soter. He was king of Egypt 322-305 BC. "One of his princes" (that is, one of Alexander's princes) is the king of Syria (Seleucus). The king of Egypt gained power over the king of the Syria. He seized control of Jerusalem from Syria (see Josephus, A XII,1). Egypt is called the South, and Syria is called the North. (Barnes, Henry, Gill, Clark, and Calvin agree).

The Visions of Daniel

Dan 11:

6 And at the end of some years they shall join forces, for the daughter of the king of the South shall go to the king of the North to make an agreement; but she shall not retain the power of her authority, and neither he nor his authority shall stand; but she shall be given up, with those who brought her, and with him who begot her, and with him who strengthened her in those times. (NKJV).

Historical Fulfillment:

Syria and Egypt attempted to join forces. Berenice was the daughter who was given in marriage to the king of Syria (the North). The other wife of the king of Syria, Laodiceia, killed both Berenice and her husband.

Dan 11:

7 But from a branch of her roots one shall arise in his place, who shall come with an army, enter the fortress of the king of the North, and deal with them and prevail (NKJV).

Historical Fulfillment:

The brother of Berenice (a branch of her roots) arose in the place of his father, invaded Syria, and killed Laodiceia.

Dan 11:

8 And he shall also carry their gods captive to Egypt, with their princes and their precious articles of silver and gold; and he shall continue more years than the king of the North.

9 Then the king of the North shall come to the kingdom of the king of the South, but shall return to his own land (NKJV).

Historical Fulfillment:

Seleucus Callinicus , the king of Syria (the king of the North), was defeated by Egypt (the king of the South).

Dan 11:

10 However his sons shall stir up strife, and assemble a multitude of great forces; and one shall certainly come and overwhelm and pass through; then he shall return to his fortress and stir up strife.

11 And the king of the South shall be moved with rage, and go out and fight with him, with the king of the North, who shall muster a great multitude; but the multitude shall be given into the hand of his enemy.

12 When he has taken away the multitude, his heart will be lifted up; and he will cast down tens of thousands, but he will not prevail.

The Visions of Daniel

13 For the king of the North will return and muster a multitude greater than the former, and shall certainly come at the end of some years with a great army and much equipment.

14 And in those times many shall rise up against the king of the South; also certain violent men of your people shall exalt themselves in fulfillment of the vision, but they shall fall (NKJV)

Historical Fulfillment:

Antiochus (not Antiochus Epiphanes) is the king of the North. After 13 years, Antiochus goes against Egypt again. "Certain violent men of your people" (vs.14) probably refers to the Jews who rebelled against Egypt and sided with Syria.

Dan 11:

15 So the king of the North shall come and build a siege mound, and take a fortified city; and the forces of the South shall not withstand him. Even his choice troops shall have no strength to resist.

16 But he who comes against him shall do according to his own will, and no one shall stand against him. He shall stand in the Glorious Land with destruction in his power (NKJV).

Historical Fulfillment:

"He who comes against him" seems to refer to Antiochus against Egypt. On his return from Egypt, Antiochus invaded the Holy Land and did damage.

Dan 11:

17 He shall also set his face to enter with the strength of his whole kingdom, and upright ones with him; thus shall he do. And he shall give him the daughter of women to destroy it; but she shall not stand with him, or be for him (NKJV).

Historical Fulfillment:

Antiochus gave his daughter to Ptolemy, the king of Egypt, in order to strengthen a political alliance, but she betrayed her father ("she shall not stand with him") and sided with her husband.

Dan 11:

18 After this he shall turn his face to the coastlands, and shall take many. But a ruler shall bring the reproach against them to an end; and with the reproach removed, he shall turn back on him (NKJV).

The Visions of Daniel

Historical Fulfillment:

Antiochus turned "his face to the coastlands," and took some islands of the Mediterranean, but was defeated by Rome.

Dan 11:

19 Then he shall turn his face toward the fortress of his own land; but he shall stumble and fall, and not be found (NKJV).

Historical Fulfillment:

The power of Antiochus was then eclipsed. His power declined.

Dan 11:

20 There shall arise in his place one who imposes taxes on the glorious kingdom; but within a few days he shall be destroyed, but not in anger or in battle (NKJV).

Historical Fulfillment:

Seleucus Philopator, of Syria, arose in the place of Antiochus and imposed taxes on Judea.

Dan 11:

21 And in his place shall arise a vile person, to whom they will not give the honor of royalty; but he shall come in peaceably, and seize the kingdom by intrigue (NKJV).

Historical Fulfillment:

Antiochus Epiphanes IV (a "vile person" - the "little horn" of Chapter Eight) seizes the throne of Syria (175 BC).

Certainly Antiochus was obsessed with his own importance, as his coins prove conclusively. Bearing early in his reign his own portrait and the inscription "King Antiochus", they become increasingly pretentious, with the addition of such symbols as a star above the king's head, and the words "God Manifest" (Epiphanes) attached to a portrait with the features of Apollo or, later, Zeus, crowned with laurels or with the sun's rays. Polybius makes reference to popular reaction to his self-adorned title; "Antiochus surnamed Epiphanes gained the name of Epimanes [madman] by his conduct" (Book 26).³¹

³¹ Baldwin, Joyce G. *Daniel, An Introduction & Commentary*, Downer's Grove, ILL: InterVarsity Press, 1978

The Visions of Daniel

Dan 11:

22 With the force of a flood they shall be swept away from before him and be broken, and also the prince of the covenant (NKJV).

Historical Fulfillment:

He (Antiochus Epiphanes) "swept away" foreign armies. He also removed the high priest that descended from Zadoc (the prince of the covenant).

Dan 11:

23 And after the league is made with him he shall act deceitfully, for he shall come up and become strong with a small number of people.

24 He shall enter peaceably, even into the richest places of the province; and he shall do what his fathers have not done, nor his forefathers: he shall disperse among them the plunder, spoil, and riches; and he shall devise his plans against the strongholds, but only for a time (NKJV).

Historical Fulfillment:

Antiochus Epiphanes distributes welfare. Many tyrants such as Caesar, Hitler, Lenin, and Castro have used this method of extorting the produce of some to distribute to others and gain power. People can be bought.

Dan 11:

25 He shall stir up his power and his courage against the king of the South with a great army. And the king of the South shall be stirred up to battle with a very great and mighty army; but he shall not stand, for they shall devise plans against him (NKJV).

Historical Fulfillment:

This is a prophecy that Antiochus Epiphanes (the little horn) would conquer Egypt and he did.

Dan 11:

26 Yes, those who eat of the portion of his delicacies shall destroy him; his army shall be swept away, and many shall fall down slain (NKJV).

Historical Fulfillment:

The army of the king of Egypt was defeated. "His army" means the army of the king of Egypt.

The Visions of Daniel

Dan 11:

27 Both these kings' hearts shall be bent on evil, and they shall speak lies at the same table; but it shall not prosper, for the end will still be at the appointed time. While returning to his land with great riches, his heart shall be moved against the holy covenant; so he shall do damage and return to his own land (NKJV).

Historical Fulfillment:

Encouraged by victory over Egypt, Antiochus Epiphanes passes through Jerusalem on his way to Syria, and takes the holy vessels from the Temple.

Dan 11:

28 "While returning to his land with great riches, his heart shall be *moved* against the holy covenant; so he shall do *damage* and return to his own land.

29 At the appointed time he shall return and go toward the south; but it shall not be like the former or the latter (NKJV).

Historical Fulfillment:

Antiochus invaded Egypt again, but Rome came against him. He then went to Jerusalem, put an idol of his god in the Temple, and sacrificed a pig on the altar.

Dan 11:

30 For ships from Cyprus shall come against him; therefore he shall be grieved, and return in rage against the holy covenant, and do damage. So he shall return and show regard for those who forsake the holy covenant (NKJV).

Historical Fulfillment:

Clark's Commentary says the following.

Chittim is well known to mean the *Roman empire*. Antiochus, being now in full march to besiege Alexandria, and within *seven miles* of that city, heard that ships were arrived there from Rome, with *legates* from the senate. He went to salute them. They delivered to him the letters of the senate, in which he was commanded, on pain of the displeasure of the Roman people, to put an end to the war against his nephews. Antiochus said he would go and consult his friends; on which *Popilius*, one of the legates, took his staff, and instantly drew a circle round Antiochus on the sand where he stood, and commanded him not to pass that circle till he had given a definitive answer. Antiochus, intimidated, said, *he would do whatever the senate enjoined*; and in a few days after began his march, and returned to Syria. This is confirmed by *Polybius*, *Livy*, *Velleius*, *Paterculus*, *Valerius Maximus*, and *Justin*.

The Visions of Daniel

Dan 11:

31 And forces shall be mustered by him, and they shall defile the sanctuary fortress; then they shall take away the daily sacrifices, and place there the abomination of desolation (NKJV).

Historical Fulfillment:

The Temple lay desolate for three years and weeds grew up in the court of the Temple. The “abomination of desolation” was the idol put there.

Dan 11:

32 Those who do wickedly against the covenant he shall corrupt with flattery; but the people who know their God shall be strong, and carry out great exploits (NKJV).

Historical Fulfillment:

Jewish traitors conspired with the enemy against God and the Maccabees.³³ The Maccabees carried out great exploits at this time. They won some great victories against impossible odds and recovered the Temple after three years. Their rebellion against authority was warranted in this case because a higher authority demanded it. The little horn was determined to stamp out the knowledge of Jehovah. The Jews were not allowed to circumcise their children, and were forced to offer incense to false gods. The Maccabees withstood Antiochus Epiphanes. They defeated him in some battles, but many fell.

Dan 11:

33 And those of the people who understand shall instruct many; yet for many days they shall fall by sword and flame, by captivity and plundering.

34 Now when they fall, they shall be aided with a little help; but many shall join with them by intrigue.

35 And some of those of understanding shall fall, to refine them, purge them, and make them white, until the time of the end; because it is still for the appointed time (NKJV).

God has an appointment book and he keeps his appointments as Habakkuk says:

³³ See Appendix B, The Maccabees.

The Visions of Daniel

For the vision is yet for an appointed time; but at the end it will speak, and it will not lie. Though it tarries, wait for it; Because it will surely come, it will not tarry (Hab 2:3 NKJV)

And he said, "Look, I am making known to you what shall happen in the latter time of the indignation; for at the appointed time the end shall be" (Dan 8:19 NKJV)

The actual end of this appointed time took place in A.D. 70 when "the power of the holy people was completely shattered" (Dan 12:7).

Dan 11:

36 Then the king shall do according to his own will: he shall exalt and magnify himself above every god, shall speak blasphemies against the God of gods, and shall prosper till the wrath has been accomplished; for what has been determined shall be done (NKJV).

Historical Fulfillment:

Most orthodox scholars agree on the interpretation of this chapter up to verse 36. After this verse there are differences. Some say the "king" in this verse is Antiochus IV, and continues to the end of the chapter. The problem with this is that Antiochus did not do the things mentioned in these verses. Therefore, the unbelieving scholars say that Daniel was a false prophet. Antiochus IV Epiphenes did not honor a foreign god (as did Rome). He did not fight both the king of the South and the king of the North (as did Rome), and did not have power over Libya (as did Rome).

"The king" in verse 36 is Rome, according to John Calvin. The angel is giving Daniel a bare outline of history foretold. After Antiochus Epiphenes, Rome is the next big chronological "event." Only Rome and/or Herod under Rome fit the historical fulfillment.

Rome (the Julio/Claudian line of Caesars in particular) spoke blasphemies against God by declaring themselves as gods. He (the principality over the

The Visions of Daniel

Julio/Claudian dynasty) prospered until "the wrath" was accomplished with the destruction of Jerusalem. God had determined it to happen and promised that it would be accomplished.

James Jordan says that this "king" is the same as the little horn of Chapter Seven.

In fact, the Willful King seems rather clearly to be positioned between the North and the South. Philip Mauro, and before him the Scottish exegete James Farquharson, urged that this person is Herod the Great, and possibly the line of Herods thereafter. Mauro, *The Seventy Weeks and the Great Tribulation* (Swengel, PA: Reiner Pubs, 1944). Mauro's exegesis makes far more sense than anyone else's, and thus I present a refinement of it here.

Ultimately, the question boils down to what fits best. We take this passage and the description of the Second Little Horn [of Chapter 7], and we compare them with the Caesars and with Herod. We also compare the general redemptive-historical context with each. Then we see which fits best. I submit that Herod fits best.

Virtually the only persons ever called kings in the New Testament are the Herods.

Herod the Great was the "face" of Rome to the Jews, thus the primary face that the fourth beast shows is that of the Second Little Horn. [The first was the one in Chapter Eight, Antiochus IV.] Herod had been made "king of the Jews" by the Roman Senate in 39 BC.³⁴

Dan 11:

37 He shall regard neither the God of his fathers nor the desire of women, nor regard any god; for he shall magnify himself above them all (NKJV).

Historical Fulfillment:

Rome did not regard the God of its fathers. It was agnostic and atheist in practice. The desire of women could refer to Caesar's homosexual tendencies or it could mean that Rome had no mercy like women might have. Rome magnified itself above all. Rome required the allegiance that cried, "Hail Caesar," and "We have no king but Caesar!" As quoted earlier, Augustus Caesar said, "There is no other name under heaven given among men whereby we must be saved, but the name Caesar."

James Jordan applies this to Herod, the Roman puppet.

³⁴ Jordan, James B. *Daniel*. Niceville, Florida: Biblical Horizons, 1994

The Visions of Daniel

It is more likely that the “desire of women” is a reference to the Messiah. Haggai 2:7 calls the Messiah the “Desire of nations,” and in the light of Genesis 3:15, the Messiah could properly be called the “Desire of women.” A third possibility, which does not exclude the second just mentioned, is that the desire of women is children. “Give me children or I die:” was the prayer of more than one woman in the history of Israel. Herod’s slaughter of the infants in Bethlehem showed that he had no regard for the desire of women.³⁵

Dan 11:

38 But in their place he shall honor a god of fortresses; and a god which his fathers did not know he shall honor with gold and silver, with precious stones and pleasant things.

39 Thus he shall act against the strongest fortresses with a foreign god, which he shall acknowledge, and advance its glory; and he shall cause them to rule (NKJV).

Historical Fulfillment:

Rome had a policy of acknowledging the gods of conquered peoples. They even honored the God of the Jews and required that the Jews offer sacrifices and prayers for Rome. If it refers to Herod, he was an Edomite, had switched religions (outwardly at least), and honored the God of the Jews. It could refer to both Herod and Rome. Perhaps the angel envisions one principality over both instead of mere men.

Dan 11:

40 At the time of the end the king of the South shall attack him; and the king of the North shall come against him like a whirlwind, with chariots, horsemen, and with many ships; and he shall enter the countries, overwhelm them, and pass through (NKJV).

Historical Fulfillment:

The Geneva Commentary says that both the South (Egypt) and the North (Syria) resisted Rome, but Rome prevailed.

Dan 11:

41 He shall also enter the Glorious Land, and many countries shall be overthrown; but these shall escape from his hand: Edom, Moab, and the prominent people of Ammon (NKJV).

³⁵ Jordan, James B. *Daniel*. Niceville, Florida: Biblical Horizons, 1994

The Visions of Daniel

Historical Fulfillment:

The Roman general Pompey took Jerusalem around 63 BC. He had been invited by one of the warring factions of the Jews. Rome brought order at last to the chaotic division and warring factions among the Jews. Rome also protected the Jews from their enemies.

Octavian entered Palestine, where Herod switched sides and allied with him. Then Octavian sent an expedition into Edom, Moab, and Ammon under Aelius Gallus, who was joined by men from Herod, but the expedition was unsuccessful.³⁶

Dan 11:

42 He shall stretch out his hand against the countries, and the land of Egypt shall not escape (NKJV).

Historical Fulfillment:

Egypt was brought into subjection by Julius Caesar in 30 BC and again by Octavian later.

Dan 11:

43 He shall have power over the treasures of gold and silver, and over all the precious things of Egypt; also the Libyans and Ethiopians shall follow at his heels (NKJV).

Historical Fulfillment:

Rome conquers the world and secures world peace in the days of Augustus Caesar (Octavian). Christ was born at this time (4 BC).

Dan 11:

44 But news from the east and the north shall trouble him; therefore he shall go out with great fury to destroy and annihilate many (NKJV).

Historical Fulfillment:

Civil war broke out in Britain and Palestine at the time of Nero around A.D. 66.

³⁶ Jordan, James B. *Daniel*. Niceville, Florida: Biblical Horizons, 1994

The Visions of Daniel

Dan 11:

45 And he shall plant the tents of his palace between the seas and the glorious holy mountain; yet he shall come to his end, and no one will help him (NKJV).

Historical Fulfillment:

Caesar planted the tents of his palace in Palestine between the Mediterranean Sea and Jerusalem (“between the seas and the glorious holy mountain”). It does not say he planted his palace. He planted the *tents* of his palace. He did this by sending the Roman General Vespasian to Palestine. This seems to be the invasion of Palestine in A.D. 66. The Jewish War began at that time (the beginning of the end). Nero and the Julio/Claudian dynasty came to an end in A.D. 68 when Nero (the beast incarnate) committed suicide.

The Geneva Commentary interprets verse 45 as follows.

The Romans after this reigned quietly throughout all countries, and from sea to sea, and in Judea: but at length because of their cruelty God will destroy them.

The Visions of Daniel

CHAPTER SEVEN

Daniel Chapter 12

One must know history in order to interpret prophecy. Josephus, 1st Maccabees, and Eusebius are the main historical sources for the period from Cyrus to A.D. 70. Until one knows history and is inspired by the Spirit, the book of Daniel is still sealed. With the phrase, “at that time,” Chapter 12 carries on the chronological sequence of events that were to follow the invasion by Rome in the last verse of Chapter 11 when he planted his tents in Palestine, and culminates with the complete shattering of the power of the holy people in 12:7.

Dan 12:

1 At that time Michael shall stand up, the great prince who stands watch over the sons of your people; And there shall be a time of trouble, such as never was since there was a nation, even to that time. and at that time your people shall be delivered, every one who is found written in the book (NKJV).

Notice that it says, “At that time.” At what time? At the next chronological event proceeding from chapter eleven! This *time of trouble* is called the Great Tribulation period referenced by Jesus in Matthew 24:21.

For then there will be great tribulation, such as has not been since the beginning of the world until this time, no, nor ever shall be (Mt 24:21 NKJV).

Jesus said that it would take place in that generation (Mat 24:34). His word proved to be true when it began in A.D. 66, and lasted for 3 1/2 years. It was when the Jews rebelled against Rome and received the likes of Barabbas in the form of “thieves” and zealots. Rome invaded Palestine and destroyed Jerusalem. Jesus referred to it as a time of trouble such as never before or after. He indicated in

The Visions of Daniel

Matthew 24 and Luke 21 that it would start when the armies were gathered around Jerusalem (the abomination of desolation). That was fulfilled in A.D. 66.

Verse one says, "your people shall be delivered." Daniel's people (God's people) were delivered from the persecuting Jews and Nero at that time.

Dan 12:

2 And many of those who sleep in the dust of the earth shall awake, some to everlasting life, some to shame and everlasting contempt.

3 Those who are wise shall shine like the brightness of the firmament, and those who turn many to righteousness like the stars forever and ever (NKJV).

It says "many of those who sleep in the dust of the earth shall awake." At that time, many Old Testament people who had died would be raised from the dead. Those whose names were not found written in the book of life would be cast into the lake of fire (Rev 20:11ff).

Up until the coming of Christ, no one had ascended bodily to heaven. "No one has ascended to heaven but He who came down from heaven, that is, the Son of Man who is in heaven" (John 3:13). The dead were disembodied spirits waiting in Hades for the coming of Christ and the resurrection (See Luke 16:22,23 on the rich man and Lazarus). Those who came forth with Christ in Matthew 27:52 were the first fruits. Daniel also tells us it would happen at the time of trouble when he says again, "Many of those who sleep in the dust of the earth shall awake" (Dan 12:1,2).

Dan 12:

4 But you, Daniel, shut up the words, and seal the book until the time of the end; many shall run to and fro, and knowledge shall increase" (NKJV).

The "time of the end" refers to when all these things mentioned here would be finished. The end of the world is nowhere mentioned in Daniel.

The Visions of Daniel

Verse 4 says "knowledge shall increase." This refers to the "unveiled faces" of the apostles (2 Cor 3:13-18). They unveiled the "mystery that was hidden from the ages" (Col 1:26).

The mystery which has been hidden from ages and from generations, but now has been revealed to His saints" (Col 1:26 NKJV).

The fact that the apostles and Jesus unsealed the hidden meaning of the Old Testament is proof that they lived at the time of the end. The apostles unveiled the glory of God that was reflected in their faces.

But we all [unlike Moses], with unveiled face, beholding as in a mirror the glory of the Lord, are being transformed into the same image from glory to glory, just as by the Spirit of the Lord (2Cor 3:18 NKJV).

Verse 4 says to "seal the book until the time of the end." The book would not be understood until the time of the end. At that time it would be unsealed. The Lamb of God is pictured in Revelation as being found worthy to unseal the book. He then proceeded to unseal it because the time of the end had arrived (Rev 4 & 5).

Dan 12:

5 Then I, Daniel, looked; and there stood two others, one on this riverbank and the other on that riverbank.

6 And one said to the man clothed in linen, who was above the waters of the river, "How long shall the fulfillment of these wonders be?" (NKJV).

Verse eleven will give the answer to this question of "How long." It was to be in 3 1/2 years (a time, times, and half a time). When the power of the holy people (the Temple) was completely shattered, all these things would be finished (v. 7). That took place in A.D. 70.

The Visions of Daniel

When we die, we are raised and go to the scene in Rev. 20:11ff.³⁷ It is a literal resurrection, a new spiritual body (not a spirit) sown in corruption but raised in incorruption (1 Cor 15:42).

Dan 12:

7 Then I heard the man clothed in linen, who was above the waters of the river, when he held up his right hand and his left hand to heaven, and swore by Him who lives forever, that it shall be for a time, times, and half a time; and when the power of the holy people has been completely shattered, all these things shall be finished (NKJV).

A "time, times, and half a time" is interpreted by many to mean three and one half years. A time is one year, times is two years, half a time is half a year. That is exactly how long the Jewish war with Rome lasted. (From the Spring of A.D. 66 to September of A.D. 70.) This answered Daniel's question in vs. 6. "How long shall be the fulfillment of these wonders?"

What else could the "power of the holy people" be but the Temple and Jerusalem? Both were completely shattered in A.D. 70. This had to happen as the sign of His coming (the sign that Christ had come). It also signified the end of the age (the Old Testament age) and the coming of His Kingdom. Not everyone saw Him raised from the dead, but *through this sign*, every eye saw Him coming on the clouds to the Ancient of Days. When would this happen? It says it would happen "when the power of the holy people has been completely shattered, all these things shall be finished."

³⁷ Then I saw a great white throne and Him who sat on it, from whose face the earth and the heaven fled away. And there was found no place for them. And I saw the dead, small and great, standing before God, and books were opened. And another book was opened, which is the Book of Life. And the dead were judged according to their works, by the things which were written in the books. The sea gave up the dead who were in it, and Death and Hades delivered up the dead who were in them. And they were judged, each one according to his works. Then Death and Hades were cast into the lake of fire. This is the second death. And anyone not found written in the Book of Life was cast into the lake of fire (Rev 20:11-15 NKJV).

The Visions of Daniel

If the Jews were Daniel's "holy people," and if their power was "completely shattered" in A.D. 70, then we must conclude that all of these things *were* finished by the time the Temple was destroyed. What things were finished? The five things he had just mentioned in the preceding verses:

1. The Great Tribulation (vs. 1)

At that time Michael shall stand up, the great prince who stands watch over the sons of your people; And there shall be a time of trouble, such as never was since there was a nation, even to that time. and at that time your people shall be delivered, every one who is found written in the book (Dan 12:1 NKJV).

2. The resurrection of many (vs. 2)

And many of those who sleep in the dust of the earth shall awake, some to everlasting life, some to shame and everlasting contempt. Those who are wise shall shine like the brightness of the firmament, and those who turn many to righteousness like the stars forever and ever (Dan 12:2,3 NKJV).

3. The knowledge of the apostles (vs. 3,4 & 10)

But you, Daniel, shut up the words, and seal the book until the time of the end; many shall run to and fro, and knowledge shall increase" (Dan 12:4 NKJV).

Many shall be purified, made white, and refined, but the wicked shall do wickedly; and none of the wicked shall understand, but the wise shall understand. (Dan 12:10 NKJV).

4. The abomination of desolation (v.11)

And from the time that the daily sacrifice is taken away, and the abomination of desolation is set up, there shall be one thousand two hundred and ninety days (Dan 12:10,11 NKJV).

5. The taking away of the daily sacrifice (v.11)

Although I heard, I did not understand. Then I said, "My lord, what shall be the end of these things?" (Dan 12:8 NKJV).

"What shall be the end of these things?" That is the question many ask when they discover that these things were already fulfilled. The answer is, "The Kingdom of God shall be the 'end-zone' of all these things." The subjection of all nations to

The Visions of Daniel

Christ is the end and goal of all these things. The "matter on the platter" right now is the conversion of the nations. We are to now disciple all nations.

Dan 12:

9 And he said, "Go your way, Daniel, for the words are closed up and sealed till the time of the end" (NKJV).

At the time of the end, when John wrote Revelation,³⁷ about A.D. 64-66, Jesus unsealed the seven seals of the prophecy because it was about to be fulfilled. John was also commanded *to not* seal the prophecy because it was about to take place shortly (Rev. 22:10). Daniel was told *the opposite* because it would not be fulfilled for over 600 years. "[T]he words are closed up and sealed till the time of the end."

Dan 12:

10 Many shall be purified, made white, and refined, but the wicked shall do wickedly; and none of the wicked shall understand, but the wise shall understand.

11 And from the time that the daily sacrifice is taken away, and the abomination of desolation is set up, there shall be one thousand two hundred and ninety days (NKJV).

The "abomination of desolation" was when the Roman armies gathered around Jerusalem in A.D. 66. Jesus had prophesied this event in Matthew 24 and Luke 21. In Matthew 24:15,16,21 Jesus says, "When you see the 'abomination of desolation,' spoken of by Daniel the prophet, standing in the holy place" (whoever reads, let him understand), then let those who are in Judea flee to the mountains... For then there will be great tribulation, such as has not been since the beginning of the world until this time, no, nor ever shall be." But Luke says, "When you see Jerusalem surrounded by armies, then know that its desolation is near. Then let those in Judea flee to the mountains, let those who are in the midst of her depart, and let not those who are in the country enter her. For these are the days of vengeance, that all things

³⁷ In his book, *Before Jerusalem Fell*, The Institute for Christian Economics, Tyler, Texas, Kenneth Gentry proves that Revelation was written before Jerusalem fell in A.D. 70.

The Visions of Daniel

which are written may be fulfilled" (Luke 21:21-22). What Matthew calls "abomination of desolation," Luke calls "Jerusalem surrounded by armies." Three and one half years later Jerusalem was destroyed and the daily sacrifice of the Temple was taken away forever. One thousand two hundred and ninety days is just over three and a half years. Josephus also tells us that the Jews ceased to make sacrifices for Rome at the beginning of the three and a half year war, and that was what brought down the wrath of Rome.

When Cestius first surrounded Jerusalem with armies in A.D. 66, the Christians in Jerusalem remembered the prophecy of Jesus. But they could not at first escape the city because of the Roman armies. Josephus tells us that for some unknown reason, Cestius pulled his troops out and headed for the sea. The Jewish rebels followed him with ambushes, killed thousands of Romans, and captured much of their supplies and weapons. By this means, God sent them a strong delusion just as Paul had prophesied in II Thessalonians 2:11. They actually now believed that they could defeat the mightiest empire the world had ever known.

And for this reason God will send them strong delusion, that they should believe the lie (2Thess 2:11).

When Cestius retreated the Christians in Jerusalem took the opportunity to escape the city as Jesus had warned. Eusebius tells us they escaped to a city on the other side of the Jordan called Pella. This was their "rapture." They were "left behind" like Noah and Lot. Isaiah says, "*he who is left in Zion and remains in Jerusalem will be called holy*" (Isa 4:3 NKJV). True believers in Christ have come to Mount Zion, the Heavenly Jerusalem (Heb 12:22). They are the remnant.

The Visions of Daniel

Dan 12:

12 Blessed is he who waits, and comes to the one thousand three hundred and thirty-five days (NKJV).

By the time 1335 days had passed (45 more days than 1290), from the beginning of the Jewish rebellion, the siege of Jerusalem was over, and the city was plowed up in A.D. 70. This could mean that Jerusalem was destroyed at the end of the 1290 days, and forty-five days later, the city was plowed up. There was peace in the land at last.³⁸ Josephus tells us that one would not have known a city had been there unless the Romans had left three towers standing so that people would know.

Dan 12:

13 But you, go your way till the end; for you shall rest, and will arise to your inheritance at the end of the days (NKJV).

The “end of the days” refers to the 1335 days mentioned in the preceding verse. That is, 1335 days after the abomination of desolation (the Roman armies surrounding Jerusalem) had stood in the holy place in A.D. 66. Daniel was to arise from the dead at this time. If this interpretation is true, he did arise in A.D. 70. At that time the Lord descended from heaven with a shout, with the voice of the archangel and the trumpet of God. The dead were raised at that time. We who are living shall also be caught up with them in the clouds, after we die. So shall we ever be with the Lord (1 Thess 4:16,17). This will also happen to the living at Christ’s final return to earth. “We shall not all sleep, but we shall all be changed” (1 Cor 15:51).

Our old corrupt body is sown in corruption. It remains in the earth and rots just as a seed does. But just as the rotting seed shoots forth a new plant, so this

³⁸ There were still rebel Jews hiding at Machaerus (Herod's desert fortress where John the Baptist was beheaded) and the mountain top refuge of Masada. It took the Romans three and a half more years to build a ramp to the top of the mountain and get rid of them.

The Visions of Daniel

corrupt body will shoot forth a new incorrupt body. This new body is a spiritual body. It is not just a spirit, but it is a spiritual body. The reason that the body of Jesus did not remain in the grave is because it was not sown in corruption since He was sinless.

So also *is* the resurrection of the dead. *The body* is sown in corruption, it is raised in incorruption (1Co 15:42 NKJV).

Now this I say, brethren, that flesh and blood cannot inherit the kingdom of God; nor does corruption inherit incorruption (1Co 15:50 NKJV).

For this corruptible must put on incorruption, and this mortal *must* put on immortality (1Co 15:53 NKJV).

So when this corruptible has put on incorruption, and this mortal has put on immortality, then shall be brought to pass the saying that is written: "Death is swallowed up in victory" (1Co 15:54 NKJV).

Conclusion to Chapter Twelve

One now clearly sees that all of the prophecies of Daniel tie together and were fulfilled. They all aim at the "filling up of the cup of wrath" and the destruction of the beast (Caesar) and Jerusalem. (In Revelation they are called the beast and the false prophet.) This seems to be what is called "the end." All of this is pictured as taking place at the time of the fourth beast (civil Rome). At the end, the kingdom of God came just as John the Baptist and Jesus said it would. The coming of the kingdom of God would bring the resurrection. If this interpretation is correct, then this all took place in A.D. 70. The author can find no gap of thousands of years unless it is imposed on the text from some other source unknown to this author.

The Visions of Daniel

Jesus said the resurrection would come in the "last day."³⁹ We are now living in that day according to Acts 2:17. If this interpretation is correct, the resurrection must have begun in A.D. 70 and continued since then. It is the age of the Messiah. It must culminate in total victory for God's people. Heaven will come to earth and there will be no more dying.

Chapter Seven shows the little horn persecuting the saints for three and a half years (interpreted here as Nero's persecution), the ascension of the Son of Man to the Ancient of Days, and the coming of the kingdom of God. At that time Chapter Eight foretells the trouble with the other little horn, Antiochus Epiphanes (175 BC). Chapter Nine foretells the seventy weeks, the death of Messiah, and the destruction of Jerusalem ("shall destroy the city and the sanctuary" 9:26). Christ appears alive in chapter ten and then an angel foretells the troubles during the Inter-Testamental period and the coming of Rome in Chapter Eleven. Chapter Twelve deals with the Great Tribulation, the length of it, the shattering of the holy people, and the promise of the resurrection.

God gave us this information beforehand so that we would believe when it was fulfilled (Jn 16:4). This is evidence that Jesus Christ is the Son of God. This is evidence of Divine inspiration, and that the prophets and Christ were true and faithful witnesses.

If God fulfilled these things in those days, this is token evidence that He will fulfill the promise that the earth shall be filled with the knowledge of the glory of the Lord as the waters cover the sea (see Hab. 2:14).

³⁹ No one can come to Me unless the Father who sent Me draws him; and I will raise him up at the last day (John 6:44 NKJV).

The Visions of Daniel

If you were a devout Jew like Anna "waiting for the redemption in Jerusalem" (Luke 2:38) in the days of Christ, you would be looking for those things to be fulfilled soon. Your heart would leap within when you heard John the Baptist say, "Repent. For the kingdom of God is at hand." You would be expecting the "days of vengeance, that all things which are written may be fulfilled" (Luke 21:22 NKJV). If this thesis is true, then these things *were* fulfilled in that generation just like Jesus had prophesied, the end of "all things" *did* come with the destruction of Jerusalem, and *that* was the sign of His coming and the end of the age. The apostles were living in the last days of the only age they knew. They were the last days of the Old Testament age. But we are not living in the last days. We are living in the last day. As Charles Spurgeon said, "We are now living in the time of the new heavens and the new earth."

It cannot be overemphasized that these events are pictured as being fulfilled in the days of the fourth beast. "In the days of these kings the God of heaven will set up a kingdom" (Dan. 2:44). The author is at a loss to find a reason for inserting a two-thousand year gap. The author must conclude that to insert a gap of thousands of years between the 69th and 70th weeks is really "stretching it like a rubber band." All these things were to be fulfilled when the "power of the holy people" would be completely shattered (Dan. 12:7). Can it be denied that their power was completely shattered in A.D. 70?

The Visions of Daniel

CHAPTER EIGHT Summary of Daniel's Visions

In Daniel chapter 2, the king of Babylon had a dream, which Daniel interpreted. He saw the image of a man with a head of gold, arms and chest of silver, belly of brass, legs of iron and feet part iron and part clay. Daniel interpreted the dream. The author sees the head of gold as Babylon, the silver as Medo/Persia, the brass as Greece, and the legs as Rome. The feet mixed with iron and clay illustrate that man's kingdoms have "feet of clay." Humanism, that is, the worship of Caesar (the state) has a faulty foundation.

And in the days of these kings the God of heaven will set up a kingdom which shall never be destroyed; and the kingdom shall not be left to other people; it shall break in pieces and consume all these kingdoms, and it shall stand forever (Dan 2: 44 NKJV).

Daniel 2:44 says that God would set up His kingdom "in the days of these kings." To which kings is he referring? It must refer to the kings just mentioned in the king's dream. If the head was Babylon and the legs and feet are Rome, then the Kingdom of God was predicted to come during the time of the Roman Empire.

"[I]t shall break in pieces and consume all these kingdoms"

This is what has been happening since Christ came. As Isaiah says, "For the nation and kingdom which will not serve you shall perish, And *those* nations shall be utterly ruined" (Isa 60:12). Zechariah 12:9 says, "It shall be in that day *that* I will seek to destroy all the nations that come against Jerusalem."

It is very clear from the text that this is not something that will start in our future. The destruction of Jerusalem and Nero (the beast) is a token of that future accomplishment. The conversion of Constantine, and the establishment of Armenia

The Visions of Daniel

and Rome as Christian nations are also tokens that what God has begun, He will finish.

Being confident of this very thing, that He who has begun a good work in you will complete *it* until the day of Jesus Christ (Phil 1:6 NKJV).

In Daniel chapter 7, Daniel prophesies the coming of the fourth beast with ten horns. The fourth beast was Rome and the ten horns are the ten provinces of Rome. Each province had a king under Caesar. He saw another little horn rise that uprooted three of the other horns. The little horn was the line of Caesars. Caesar Augustus uprooted the rulers of three provinces (Perhaps Mark Antonio, Brutus, and Casius?) and solidified the empire.

One can clearly see that this was not to happen in our future, but in the days of the Roman Empire under the dynasty of Caesar. Nero Caesar seems to be the little horn that made war with the saints for three and a half years (time, times, and half a time). The Roman Republic was not an empire until the coming of Caesar. It then was converted from a republic into a beastly empire. Nero was the last of the dynasty of Caesar. (Later kings continued with the title only as did the Kaiser of Germany, the Byzantine emperors, and the Czars of Russia.)

He shall speak *pompous* words against the Most High, Shall persecute the saints of the Most High, And shall intend to change times and law. Then *the saints* shall be given into his hand For a time and times and half a time (Dan 7:25 NKJV).

Julius Caesar is the one who changed "times and law" (the calendar).

Daniel chapter seven makes it very clear that it was in the days of the little horn (Nero) that the Son of Man would come to the Ancient of Days to receive his kingdom. In that day, judgment would come and the kingdom would be given to the "people of the saints of the Most High" (Dan 7:27 NKJV).

The Visions of Daniel

Daniel Chapter Eight speaks of a ram with two horns that was to come. The angel says, "The ram which you saw, having the two horns--*they are* the kings of Media and Persia." He then saw a goat with a large horn that did away with the ram. "And the male goat *is* the kingdom of Greece. The large horn that *is* between its eyes *is* the first king" (8:20 NKJV). The horn was then broken and four other horns came up in its place. "As for the broken *horn* and the four that stood up in its place, four kingdoms shall arise out of that nation, but not with its power" (8:21 NKJV). Alexander was the one who defeated Persia and his empire was divided between his four generals. Out of one of these four kingdoms was another small horn that was to come.

And in the latter time of their kingdom, When the transgressors have reached their fullness, A king shall arise, Having fierce features, Who understands sinister schemes. His power shall be mighty, but not by his own power; He shall destroy fearfully, And shall prosper and thrive; He shall destroy the mighty, and *also* the holy people. Through his cunning He shall cause deceit to prosper under his rule; And he shall exalt *himself* in his heart. He shall destroy many in *their* prosperity. He shall even rise against the Prince of princes; But he shall be broken without *human* means (Dan 8:23-25 NKJV).

This king came in the latter time of the Grecian division of four kingdoms. It is a fact that when Alexander died, his kingdom was divided between his four generals. Clark says the king was Rome, JFB say it is someone in our future, and Matthew Henry says it was Antiochus Epiphenes. Antiochus Epiphenes (175 B.C.) was the king of Syria (one of the four divisions of Alexander's kingdom). He rose "against the Prince of princes" when he defiled the Temple and sacrificed a pig on the altar. He "destroyed the mighty, and also the holy people" by bringing an end to the daily sacrifices of the Temple and attempting to stamp out the worship of Jehovah. It

The Visions of Daniel

could not be Rome because it says, "he shall be broken without *human* means."

Rome came to an end by human means. Antiochus died of a sickness.

This interpretation, if correct, was fulfilled about 341 years after Daniel saw it. The vision was sealed until it was fulfilled after many days in the future.

Therefore seal up the vision, For *it refers* to many days *in the future* (Dan 8:26 NKJV).

Note that we have a clear time indicator here. We also learn what "many days in the future" means to God. Some tell us that "soon" does not mean "soon" when God says it. Here we see clearly that "soon" meant "before 341 years." How could this refer to our future when it clearly (and literally) says that it would happen in the latter days of "their kingdom?" To make it mean some kingdom in our future would be to insert something into the text that is not there.

The Time of the End.

Understand, O son of man: for at the time of the end *shall be* the vision (Dan 8:17 NKJV).

When was the time of the end? It seems to be at the time of the end of their kingdom. Whose kingdom? It was the Kingdom of the four divisions of the Greek Empire. It does not refer to the "time of the end" of the world. If we are to read Scripture in context, it must have referred to the latter time of the indignation of God upon the Jews and upon the Greeks (See 8:19).

At that time Michael shall stand up, The great prince who stands *watch* over the sons of your people; And there shall be a time of trouble (Dan 12:1 NKJV).

At what time would the great tribulation come? Was it not the time indicated in the context of the previous chapter (11:36-45)? In chapter 11, Daniel foresees the various kings that would come, starting with the first kings of Persia. He then

The Visions of Daniel

proceeds chronologically with the kings of Syria. But in verse 36 he speaks of "the king," and proceeds to describe him.

This king could not be someone in our future without inserting a gap of thousands of years from somewhere outside the context of the passage. If the previous kings are in chronological order, then logic seems to demand that this king must be also. Then who is he?

Notice the characteristics of this king and let us examine who fits this description. Most agree it was not Antiochus Epiphenes because he did not do some of the things listed after verse 35. Let us see if Caesar's dynasty fits this description.

Verse 36 says, "he shall exalt and magnify himself above every god, shall speak blasphemies against the God of gods, and shall prosper till the wrath has been accomplished." Caesar received worship as a god and he prospered until Nero was destroyed.

Verse 37 says he would not regard the desire of women. Could this mean that he would ruthlessly disregard feminine compassion? The Caesars certainly did that. They also engaged in homosexual activity.

Verse 38 says he would honor a god, which his fathers did not know. It was the common practice of Rome to honor the gods of the nations that they conquered. Unlike Antiochus, they even honored the God of the Jews and demanded prayers be made for them at the Temple.

At the time of the end the king of the South shall attack him; and the king of the North shall come against him like a whirlwind, with chariots, horsemen, and with many ships; and he shall enter the countries, overwhelm *them*, and pass through. He shall also enter the Glorious Land, and many *countries* shall be overthrown (Dan 11:40,41 NKJV).

The Visions of Daniel

"The time of the end" refers to the time of the end of the divisions of the Greek Empire. The "South" is Egypt, and the "North" is Syria. Rome conquered them and then entered Jerusalem (the Glorious Land).

But news from the east and the north shall trouble him; therefore he shall go out with great fury to destroy and annihilate many (Dan 11:44 NKJV).

Following the major events of history in chronological order, the verse above could refer to the civil war that broke out at the time of Nero. Civil war broke out from as far away as Britain all the way to Palestine.

And he shall plant the tents of his palace between the seas and the glorious holy mountain; yet he shall come to his end, and no one will help him (Dan 11:45 NKJV).

When Nero sent his general to invade Judea could be when he planted the tents of his palace between the Mediterranean and Jerusalem.

At that time....

The next verse (12:1) says, "At that time ... there shall be a time of trouble, Such as never was since there was a nation, *Even* to that time." At what time? At the time when "the king" plants the tents of his palace between the sea and the Glorious Land. That happened when Rome invaded in A.D. 66. The war lasted three and a half years before Jerusalem was destroyed in A.D. 70.

Jesus referred to this verse when He said, "But when you see Jerusalem surrounded by armies, then know that its desolation is near. Then let those who are in Judea flee to the mountains, let those who are in the midst of her depart, and let not those who are in the country enter her. For these are the days of vengeance, that all things which are written may be fulfilled" (Luke 21:20ff NKJV). He clearly said that all things which were written would be fulfilled. Matthew records the same discourse

The Visions of Daniel

as, "There shall be a time of trouble, Such as never was since there was a nation, *Even* to that time" (Dan 12:1 NKJV).

Therefore when you see the 'abomination of desolation,' spoken of by Daniel the prophet, standing in the holy place" (whoever reads, let him understand), then let those who are in Judea flee to the mountains (Mat 24:15,16 NKJV).

Notice it says, "At that time." It cannot refer to a time in our future. To make it mean that is to insert something into the text that is pure speculation. It must be interpreted in context.

What else would happen at that time?

And at that time your people shall be delivered,
Every one who is found written in the book (Dan 12:1b NKJV).

Daniel's people are the true people of God. Deliverance came for them when Nero and Jerusalem were destroyed.

What else would happen at that time?

And many of those who sleep in the dust of the earth shall awake, Some to everlasting life, Some to shame *and* everlasting contempt (Dan 12:2 NKJV).

When Jesus arose, many came forth with him (Mat 27:51-53 NKJV).

What else would happen at that time? The prophecy would be unsealed.

Go *your way*, Daniel, for the words *are* closed up and sealed till the time of the end (Dan 12:9 NKJV).

Jesus unsealed the book in Revelation 6. The "time of the end" refers to the end of the tribulation period when God's people would be delivered from the Jews and from Nero's persecution. (Notice that in the book of Acts, it was the Jews alone who persecuted the Christians. Nero started his persecution in A.D. 64.)

What else would happen at that time? Daniel would be raised from the dead.

But you, go *your way* till the end; for you shall rest, and will arise to your inheritance at the end of the days (Dan 12:13 NKJV).

The Visions of Daniel

Men have been predicting the end of the world with specific dates for 2000 years. Without exception they have each been wrong. That means they believed a lie. Nowhere does the Bible teach that Jesus is coming soon in our time. It says that He would come soon and he did. He said that all those things would be fulfilled in that generation and they were (Mat. 24:34). Just as God came with Babylon into Egypt (Isa 19:1) and with the armies of the Medes into Babylon (Isa 13:5), He came with the armies of Rome and destroyed Jerusalem in A.D. 70.

The burden against Egypt. Behold, the LORD rides on a swift cloud, And will come into Egypt; The idols of Egypt will totter at His presence, And the heart of Egypt will melt in its midst (Isa 19:1 NKJV).

They come from a far country, From the end of heaven-- The LORD and His weapons of indignation, To destroy the whole land (Isa 13:5 NKJV).

Does this mean he will not come to earth again? By no means does it mean that. Yes he will come. The Lord's Prayer shall be answered. His kingdom shall come and His will shall be done on earth as it is in heaven. The unfulfilled prophecies concerning the conversion of the nations (Psalm 22:27) must also be fulfilled first and then the last enemy (death) shall no longer be. Then "this same Jesus, which is taken up from you into heaven, shall so come in like manner as ye have seen him go into heaven" (Acts 1:11b KJV).

All the ends of the world
Shall remember and turn to the LORD,
And all the families of the nations
Shall worship before You (Psalm 22:27 NKJV).

For the earth will be filled
With the knowledge of the glory of the LORD,
As the waters cover the sea (Hab 2:14 NKJV).

The Visions of Daniel

If these conclusions are true, what then? Instead of looking for doomsday, we look to convert the nations to Christ. God sends forth His messengers to gather and disciple His elect from one end of heaven to the other. We return to the Puritan hope of converting every culture to Christ until the knowledge of the glory of the Lord covers the earth as the waters cover the sea (Hab 2:14).

Review

Chapter 2 says clearly that the little stone would set up a kingdom in the days of "these kings" (the kings of the image) that would progressively grow into a mountain that would fill the whole earth. Chapter 7 says that the Son of Man would receive His kingdom in the days of the fourth beast (Rome), and the kingdom would be given to the "people of the saints of the Most High." The author can see absolutely no warrant for inserting a gap between the 69th and the 70th weeks of Chapter 9. The Geneva Commentary says that Christ is the One who makes the covenant.

- (a) By the preaching of the Gospel he affirmed his promise, first to the Jews, and after to the Gentiles.
- (b) Christ accomplished this by his death and resurrection.
- (c) Meaning that Jerusalem and the sanctuary would be utterly destroyed because of their rebellion against God, and their idolatry: or as some read, that the plague will be so great, that they will all be astonished at them.⁴⁰

All of this agrees with both an amillennialist and a post-mil interpretation. This author can see no warrant for a gap in the contiguous chronology between Chapter 11 and Chapter 12 (the beginning of the great tribulation). Jesus specifically said that the great tribulation would begin in "that generation" in which He lived (Mat 24:21&34).

For then there will be great tribulation, such as has not been since the beginning of the world until this time, no, nor ever shall be (Mat 24:21 NKJV)

⁴⁰ <http://eword.gospelcom.net/comments/daniel/geneva/daniel11.htm>

The Visions of Daniel

Assuredly, I say to you, this generation will by no means pass away till all these things take place (Mat 24:34 NKJV).

The Geneva Commentary⁴¹ and Rushdoony⁴² alone, of the commentaries I have read, identify the "king" of 11:36 as Rome, but The Geneva Commentary reverts back and inserts a gap between the chronology of chapter eleven and that of chapter twelve; and Rushdoony spiritualizes chapter twelve as a foretelling of all of history.

Gill and Mathew Henry⁴³ also insert a gap between Chapters 11 and 12.

The Jamieson Faucette Brown Commentary (JFB) says,

... at that time--*typically*, towards the close of Antiochus' reign; *antitypically*, the time when Antichrist is to be destroyed at Christ's coming.

JFB disagrees with The Geneva Commentary on the identity of the "king" and sees Antiochus as the king, but could have a point on the two-fold application of "typically" and "anti-typically."

Clark's commentary says,

It is generally thought by commentators that the termination of the last period [in Daniel] is the epoch of the FIRST resurrection. See Re 20:4, 5.

Scripture certainly seems to agree that the epoch of the first resurrection is, as Augustine says, now in the age of the Messiah.

Albert Barnes, a postmillennialist, says concerning the "king" of 11:36,

[M]ost interpreters suppose that the allusion here to Antiochus ceases, and that henceforward it refers to Antichrist. So Jerome, Gill, Bp Newton, and others; and so Jerome says many of the Jews understood it. The only reason alleged for this is, that there are things affirmed here of the 'king' which could not be true of Antiochus.

⁴¹ The Geneva Commentary gives no reason for jumping from Rome in the last verse of chapter eleven to sometime in the future in chapter 12:1.

<http://eword.gospelcom.net/comments/daniel/geneva/daniel11.htm>

⁴² Rushdoony, R.J. *Thy Kingdom Come*, Vallecito, CA: Ross House Books, 2001.

⁴³ Each of the commentaries quoted here can be found at <http://eword.gospelcom.net/comments/>

The Visions of Daniel

Barnes goes on to prove that the “king” was Antiochus. But he seems to be stretching it⁴⁴.

R.C. Sproul, in his book, *The Last Days According to Jesus*, agrees that the prophecies of Christ and the Great Tribulation in Matthew 24 were fulfilled in A.D. 70.

All of the pre-millennial dispensationalists put gaps in Chapter 2, 7, 9, and 12. This appears to the author to be unwarranted fanciful thinking in a hysterical effort to explain their preoccupation with a “soon coming King.” The vast majority of the Church Fathers believed that the King is already reigning until He has put all His enemies under His feet at His final appearing because He said, “All authority is given to Me in heaven and in earth.” A Man now sits at the right hand of the Father on the throne of David and the Lord (1 Chron 29:23). This author believes all the references to a “soon coming” were literally fulfilled in A.D. 70.

Gordon J. Spykman says,

Though Paul’s concern was not “to fix the time,” yet “there is every reason to believe that [he] lived in the expectation of a soon-to-be-realized *parousia*” (*Berkouwer, The Return of Christ, p. 92; see also Ridderbos, Paul, pp. 487-88; Hoekema, The Bible and the Future, p. 123.*

Many early Christians, it appears, took Christ’s prophecies at face value. But before long questions arose. How soon is “soon”? “the Lord is at hand!” (Philippians 4:5) – certainly that must mean “within reach.” “The time is near” (Revelation 1:3) – but what are we to think when “near” turns out to be far away? Had not Jesus himself declared emphatically and repeatedly that the first generation of his disciples would live to see “all these things take place” (Matthew 24:34; 10:23; Mark 9:1; 13:30)?⁴⁵

What are we to think when “near” turns out to be far away? Perhaps we should re-consider how we interpreted Him. Does God speak in “gobbledegoop,” or

⁴⁴ Barnes, Albert, *Notes on the Old Testament*, Grand Rapids, Michigan: Baker Book House, 1950.

⁴⁵ Spykman, Gordon J. *Reformational Theology*, Grand Rapids, MI: William Eerdmans Publishing Company, 1992.

The Visions of Daniel

is there a way to allow Scripture to interpret Scripture? Could not the same Holy Spirit that spoke through Isaiah be indicating the same kind of coming Jesus referred to when Isaiah said, “Behold, the LORD rides on a swift cloud, And will come into Egypt?” If that was fulfilled when Babylon defeated Egypt, What hinders the same interpretation for the invasion of Rome in A.D. 66? How about David’s description of the Lord’s coming when God delivered him from Saul and his other enemies? “He bowed the heavens also, and came down” (Psalm 18:9). How about Isaiah’s prediction of the sun, moon, and stars being put out when Babylon fell in Isaiah 13:10?

C.S. Lewis says these statements by Jesus and the Apostles are one of the “great embarrassments” to the Church. In his essay on *The World’s Last Night* he discusses the problem with the statement by Jesus that His coming would take place in that generation (Mat 24:34).

But there is worse to come. “Say what you like,” we shall be told, “the apocalyptic beliefs of the first Christians have been proved to be false. It is clear from the New Testament that they all expected the Second Coming in their own lifetime. And, worse still, they had a reason, and one which you will find very embarrassing. Their Master had told them so. He shared, and indeed created, their delusion. He said in so many words, “this generation shall not pass till all these things be done.” And He was wrong. He clearly knew no more about the end of the world than anyone else.

It is certainly the most embarrassing verse in the Bible.⁴⁶

Lewis goes on to offer his solution to the dilemma. He says that because Jesus was both man and God, his human side was mistaken. The problem with that solution is that Jesus was not giving His opinion; He was prophesying. That would make Him a false prophet. At least Lewis is honest enough to admit the problem is

⁴⁶ C. S. Lewis, *The World’s Last Night and Other Essays*, New York: Harcourt, Brace and Company, 1960, 97–98.

The Visions of Daniel

there. The solution offered here presupposes the infallible inspiration of Scripture, and offers the only logical solution the author can see. Perhaps there has been a failure to see that the prophecy *was* fulfilled in the same sense as all the other Old Testament “comings” of the Lord were fulfilled.

R.C. Sproul says Bertrand Russell used these statements of Jesus and the apostles as proof that the New Testament is a false prophecy.⁴⁷ Since Russell was operating out of the nature of the “natural man,” and could not discern spiritual things, this is the only honest conclusion to which he could possibly arrive.

It is interesting to note that nowhere in the visions of Daniel is a millennium mentioned, nor an antichrist. The little horn (Antiochus) of Chapter 8 and the little horn of Chapter Seven (Nero) are not called antichrists. Nor is there any mention of Christ’s second coming. The only coming of Christ mentioned by Daniel is His coming to the Ancient of Days (the ascension). Chapter 2 sees the Kingdom of God coming in the days of those kings (the legs of iron) and not some time in the distant future from then. There is no mention of a seven-year tribulation, either. All of these concepts are foreign to Daniel. Daniel was told to seal the prophecy because it was for a long time in the future. John, on the other hand, was told *not* to seal the prophecy because it was to happen shortly. If language means anything, then it happened shortly.

Christ’s Final Coming

So called “full preterists” deny that Christ will finally come and destroy death on earth. The author believes the Apostles’ Creed and prefers to call himself an

⁴⁷ Sproul, R.C. *The Last Days According to Jesus*, Grand Rapids, MI: Baker Books, 1998.

The Visions of Daniel

“orthodox preterist.” One can trust that the Lord’s Prayer shall be answered literally. His Kingdom shall come and His will shall be done on earth as it is in heaven. This is consistent with the whole purpose of the covenant. Paradise shall be restored as it was in the beginning. God has no plan “B.”

It appears that the disciples believed the second coming would happen in their lifetime. Many scholars believe the Holy Spirit was referring to both His parousia in A.D. 70 as a type and to His final coming as an anti-type. But the disciples had no way of knowing that until after the destruction of Jerusalem. Matthew Henry said the following about this same interpretation.

[T]his prophecy, under the type of Jerusalem's destruction, looks as far forward as the general judgment; and, as is usual in prophecies, some passages are most applicable to the type, and others to the antitype; and toward the close, as usual, it points more particularly to the latter.

Peter mentions that the prophets themselves did not always understand their own prophecies. He said they were “Searching what, or what manner of time the Spirit of Christ which was in them did signify, when it testified beforehand the sufferings of Christ, and the glory that should follow” (1Pe 1:11 NKJV).

Jesus had also told them that some standing there would not see death until they see the Son of man coming in His kingdom.

Verily I say unto you, There be some standing here, which shall not taste of death, till they see the Son of man coming in his kingdom (Mat 16:28 NKJV).

Some say the answer to that riddle is found in the very next chapter when he was transfigured. But if we call that his “coming in his kingdom,” then why should we have a hard time seeing the events of A.D. 70 as also his coming? As to his promise to fulfill the prophecies of Matthew 24 in that generation, Calvin says, “the

The Visions of Daniel

word "generation" or "age" is here being used for the men of this age.” But Clark says the following.

This generation shall not pass] h genea auth, *this race*; i.e. the Jews shall not cease from being a *distinct people*, till all the counsels of God relative to *them* and the *Gentiles* be fulfilled. Some translate h genea auth, *this generation*, meaning the persons who were then living, that they should not die before these signs, &c., took place: but though this was true, as to the calamities that fell upon the Jews, and the destruction of their government, temple, &c., yet as our Lord mentions Jerusalem's continuing to be under the power of the Gentiles till the fulness of the Gentiles should come in, i.e. till all the nations of the world should receive the Gospel of Christ, after which the Jews themselves should be converted unto God, Ro 11:25, &c., I think it more proper not to restrain its meaning to the few years which preceded the destruction of Jerusalem; but to understand it of the care taken by Divine providence to preserve them as a *distinct people*, and yet to keep them out of their own land, and from their temple service. See on Mr 13:30. But still it is literally true in reference to the destruction of Jerusalem. John probably lived to see these things come to pass; compare Mt 16:28, with Joh 21:22; and there were some rabbins alive at the time when Christ spoke these words who lived till the city was destroyed, viz. *Rabban Simeon*, who perished with the city; *R. Jochanan ben Zaccai*, who outlived it; *R. Zadoch*, *R. Ismael*, and others. See *Lightfoot*.

Gill agrees.

“Verily I say unto you, this generation shall not pass,” &c.] Not the generation of men in general; as if the sense was, that mankind should not cease, until the accomplishment of these things; nor the generation, or people of the Jews, who should continue to be a people, until all were fulfilled; nor the generation of Christians; as if the meaning was, that there should be always a set of Christians, or believers in Christ in the world, until all these events came to pass; but it respects that present age, or generation of men then living in it; and the sense is, that all the men of that age should not die, but some should live ill all these things were fulfilled; see Mt 16:28 as many did, and as there is reason to believe they might, and must, since all these things had their accomplishment, in and about forty years after this.

Logic seems to demand that if the Greek can mean both, then it seems that this prophecy *was* fulfilled in A.D. 70, but also points to the fulfillment of that Old Testament type (since the Old Testament did not really end until the Temple was destroyed). Paul said the things of the Old Testament were types (*Gr. tupos*).

Now all these things happened to them as examples [*Gr. tupos*], and they were written for our admonition, upon whom the ends of the ages have come (1Cor 10:11 NKJV).

The Visions of Daniel

Appendix A The Maccabees

In 167 BC the high priest, Onias III, died, leaving only one infant son. This left his two brothers, Jason and Menelaus, to fight for the high priesthood. Jason prevailed, but Menelaus and his followers fled to Antiochus Epiphanes.

They offered Antiochus their services as guides for an invasion of Judea, and so he now marched against Jerusalem and took it without difficulty, for the friends of Menelaus opened the gates for him. Killing many in the opposition party, he plundered the city, after which he returned to Syria.⁴⁸

Two years later, Antiochus came back to Jerusalem with his army. Having again been admitted within its walls, he treated the inhabitants with great cruelty, sparing not even those who had let him into the city. He dismantled the walls of Jerusalem, burning the finest parts of the city, and stationed a Macedonian garrison in a citadel overlooking the temple. He carried away the golden vessels and treasures of the temple, putting a stop to the sacrifices. He polluted the altar by offering up swine on it, knowing that this was against the Law of Moses. He compelled the Jews to give up their worship of God and to stop circumcising their children. Those who persisted were mutilated, strangled, or crucified, with their children hung from their necks⁴⁹

At this time there was a Jewish priest, named Mattathias, who lived in the village of Modin. He had five sons: John who was called Gaddis, Simon called Mathes, Judas called Maccabeus, Eleazar called Auran, and Jonathan called Apphus. Some of the king's men came to Modin to compel the Jews to sacrifice as he had ordered. Because Mattathias refused, saying that even if all others obeyed Antiochus' commands, he and his sons never would.⁵⁰

But another Jew came forward and sacrificed as Antiochus had commanded. Mattathias and his sons took out broad-bladed knives and cut the man down, also killing the king's officer and his soldiers. After overturning the pagan altar, Mattathias cried out, "Whoever is zealous for the laws of our country and the worship of God, let him follow me!"⁵¹

Gathering a large force, Mattathias and his men overturned the pagan altars, killed those who had sacrificed on them, and ordered all their boys circumcised. After he had been in command for a year, however, he became ill. Urging his sons to continue the noble effort he had begun, he told them to choose their brother Simon as

⁴⁸ *Josephus, The Essential Writings*,. Translated and edited by Paul L. Maier. Kregel Publications, Grand Rapids, Michigan 49501

⁴⁹ Ibid

⁵⁰ Ibid

⁵¹ Ibid

The Visions of Daniel

paternal adviser, and Maccabeus as commander, because of his courage and strength. Then he died and was buried in Modin, greatly mourned by the people.⁵²

Judas Maccabeus then drove the enemy from the country. He won four big battles against impossible odds. In one battle he defeated 47,000 men with an army of 3,000. In the fourth battle he defeated the Syrian army of 65,000 with his 10,000 men. He re-conquered Jerusalem and rebuilt the altar after the Temple had lain desolate for three years. This was a great victory. Hanukkah is still celebrated by the Jews today at Christmas time. It is also called the Feast of Dedication (John 10:22). Antiochus IV Epiphanes then died of disease. But the Jews' troubles were not over.

Josephus says, "Some of the Jewish renegades inside [Jerusalem] escaped by night and went to King Antiochus [the son of Antiochus Epiphanes], craving his help against their own countrymen. The young king was angry and collected an army of about 100,000 infantry, and 20,000 cavalry, and 32 elephants."⁵³

Antiochus then came against Jerusalem. But since he was anxious to return to Syria, he offered peace to the Jews, who accepted. But troubles, traitors, and wars continued for many years. All five of the five sons of Mattathias died violent deaths. An elephant in battle crushed Eleazer. Judas was surrounded and killed in battle. John was ambushed. Jonathon was taken captive and murdered. Simon was the last. He was assassinated in 134 BC; thirty-two years after his father had led them in righteous rebellion against Syrian tyranny.

The king of Syria corrupted those who did wickedly just as Daniel had prophesied (Dan 11:32). But the Maccabees were "aided with a little help" (Dan

⁵² Ibid

⁵³ Ibid

The Visions of Daniel

11:34 NKJV) even though for many days they fell by sword and flame, by captivity and plundering" (Dan 11:33 NKJV).

Daniel tells us that the purpose of their suffering was to "purge them, and make them white, until the time of the end; because it is still for the appointed time" (Dan 11:35 KJV). The appointed time was destined to take place over two hundred years later in A.D. 70.

The Visions of Daniel

Appendix B Early Date Authors of Revelation

Below is a list of authors who advocate an early date for Revelation taken from *Before Jerusalem Fell* by Kenneth Gentry. Gentry also lists each of the works where documentation can be found. For reasons of space, I will only list their names here.

Firmin Abauzit, Jay E. Adams, Luis de Alcasar, B. Aubé, Karl August Auberlen, Greg L. Bahnsen, Arthur Stapylaton Barnes, James Vernon Bartlet, Ferdinand Christian Baur, Albert A. Bell, Jr., Leonhard Bertholdt, Willibald Beyschlag, Charles Bigg, Friedrich Bleck, Heinrich Bohmer, Wilhelm Bousset, Frederick F. Bruce, Rudolf Bultmann, Christian Karl Josias Bunsen, W. Boyd Carpenter, S. Cheetham, David Chilton, Adam Clarke, William Newton Clarke, Henry Cowles, Berry Stewart Crebs, Karl August Credner, Samuel Davidson, Edmund De Pressense, P.S. Desprez, W.M.L. De Wette, Friedrich Dusterdieck, K.A. Eckhardt, Alfred Edersheim, George Edmundson, Johann Gottfried Eichhorn, Erbes, G.H.A. Ewald, Frederic W. Farrar, Grenville O. Field, George P. Fisher, J.A. Fitzmeyer, J. Massyngberde Ford, Hermann Gebhardt, James Glasgow, Robert McQueen Grant, James Comper Gray, Samuel G. Green, Hugo Grotius, Heinrich Ernst Ferdinand Guerike, Henry Melville Gwatkin, Henry Hammond, Harbuiug, Harduin, Harenberg, H.G. Hartwig, Karl August von Hase, Hausrath, Bernard W. Henderson, Hentenius, Johann Gottfried von Herder, J.S. Herrensneider, Adolf Hilgenfeld, David Hill, Hitzig, Heinrich Julius Holtzmann, F.J.A. Hort, John Leonhard Hug, William Hurte, A. Immer, Theodor Keim, Theodor Koppe, Max Krenkel, Johann Heinrich Kurtz, Victor Lechler, Francis Nigel Lee, Joseph B. Lightfoot, Gottfried C.F. Lucke, Christoph Ernst Luthardt, James M. Macdonald, Frederick Denison Maurice, John David Michaelis, Charles Pettit M'Ilvaine, A.D. Momigliano, Theodor Mommsen, Charles Herbert Morgan, C.F.D. Moule, John Augustus Wilhelm Neander, Sir Isaac Newton, Bishop Thomas Newton, A. Niermeyer, Alfred Plummer, Edward Hayes Plumtree, T. Randell, James J. L. Ratton, Ernest Renan, Eduard Wilhelm Eugen Reus, Jean Reville, J.W. Roberts, Edward Robinson, John A.T. Robinson, J. Stuart Russell, Philip Schaff, Johann Friedrich Schleusner, J.H. Scholten, Albert Schweigler, J.J. Scott, Edward Condon Selwyn, Henry C. Sheldon, William Henry Simcox, D. Moody Smith, Arthur Penrhyn Stanley, Rudolf Ewald Stier, Augustus H. Stong, Moses Stuart, Swegler, Milton S. Terry, Thiersch, Friedrich August Gottreu Tholuck, Tillich, Charles Cutler Torrey, Cornelis Vanderwaal, Gustaav Volkmar, Foy E. Wallace, Jr., Arthur Weigall, Bernhard Weiss, Brooke Foss Westcott, J.J. Wetstein, Karl Wieseler, Charles Wordsworth, Herbert B. Workman, Robert Young, C.F.J. Zullig.⁵⁴

⁵⁴ Gentry, Kenneth L. Jr. *Before Jerusalem Fell*, Tyler, TX: Institute For Christian Economics, 1989.

The Visions of Daniel

Bibliography

- Adams, Jay E. and Fisher, Milton C. *The Time of the End*, Hackettstown, NJ: Timeless Texts, 1994.
- Baldwin, Joyce G. *Daniel, An Introduction & Commentary*, Downer's Grove, ILL: Inter-Varsity Press, 1978
- Barnes, Albert, *Barnes' Notes*, Grand Rapids, MI: Baker Book House, 1985.
- Berkhof, Louis. *Systematic Theology*, Carlisle, Pennsylvania: Banner of Truth Trust, 1958
- Berlin, Adele and Brettler, Marc Zvi eds. *The Jewish Study Bible*, New York: Oxford, 1999
- Chilton, David. *Days of Vengeance*. Tyler, Tx: Dominion Press, 1987
- Chilton, David. *Paradise Restored*, Tyler, Tx: Dominion Press, 1999.
- DeMar, Gary. *Last Days Madness*, Atlanta, GA: American Vision, 1999.
- DeMar, Gary. *End Times Fiction*, Nashville, TN: Thomas Nelson, Inc, 2001
- Edwards, Jonathon. *The History of Redemption*, Grand Rapids, MI: Kregal Publications, 1959.
- Gentry, Kenneth L. Jr. *Before Jerusalem Fell*, Tyler, TX: Institute For Christian Economics, 1989.
- Geneva Commentary <http://eword.gospelcom.net/comments/geneva/>
- Henry, Matthew, *Matthew Henry's Commentary*, McLean, VA: MacDonald Publishing Company.
- Jamieson, Faussett, and Brown, <http://eword.gospelcom.net/comments/jfb/>
- John Darby <http://eword.gospelcom.net/comments/darby/>
- John Gill Commentary, <http://eword.gospelcom.net/comments/gill/>
- Jordan, James B. *Daniel*. Niceville, Florida: Biblical Horizons, 1994.
- Jordan, James B *Through New Eyes*, Eugene, OR: Wipf and Stock Publishers, 1999.
- Josephus, *The Works of Josephus*, Peabody, Mass: 1988.
- Kik, J. Marcellus. *An Eschatology of Victory*, Phillipsburg, New Jersey: Presbyterian and Reformed Publishing Co., 1971.
- Rushdoony, R.J. *Thy Kingdom Come*, Vallecito, CA: Ross House Books, 2001.
- Sproul, R.C. *The Last Days According to Jesus*, Grand Rapids, MI: Baker Books, 1998.
- Spykman, Gordon J. *Reformational Theology*, Grand Rapids, MI: William Eerdmans Publishing Company, 1992.
- Turabian, Kate L. *A Manual for Writers*, Chicago, ILL: University of Chicago Press, 1996.
- Williamson, Thomas. *Essays In Old Testament Prophecy*: Thomas Williamson, 3131 S. Archer Ave., Chicago, Ill. 60608, 2006.